

**CONTRACT DOCUMENTS
FOR
NORTHFIELD TOWNSHIP HALL
PARKING LOT**

**NORTHFIELD TOWNSHIP
WHITMORE LAKE, MI 48189**

OHM Advisors
34000 Plymouth Road
Livonia, Michigan 48150

0151-23-0030
March 12, 2024

Northfield Township Hall Parking Lot

Northfield Township

0151-23-0030

TABLE OF CONTENTS

Bidding Requirements

Advertisement for Bid AB-1
Instructions to Bidders..... IB-1-3
Supplemental Instructions to Bidders..... SIB-1-2
Insurance Specifications..... IS-1-4
Bid Form.....BF-1-7
Bid Guarantee..... BG-1
Bid Bond..... BB-1-3
Statement of Qualifications SQ-1-3
Subcontractor ListingSL-1-2
Iran Linked Business Certification.....IL-1-2

Contract Forms

Agreement (Contract)AG-1-6
Performance Bond..... PFB-1-4
Payment BondPYB-1-3
Maintenance and Guarantee Bond..... MG-1-2
Contractor’s Affidavit CA-1
Contractor’s Declaration CD-1
Sworn Statement..... SW-1-2

Conditions of the Contract

General Conditions.....GC-1-20

General Specifications

General Specifications..... GS-1-6

Technical Specifications

Earthwork EA-1-9
Method of Payment MP-1
Supplemental Specifications SS-1-9

Appendices

- Appendix A: Special Provision for Sidewalk, Conc, Thickened Edge
- Appendix A: Special Provision for Maintaining Traffic
- Appendix A: Special Provision for Reimbursed Permit Fees
- Appendix A: Special Provision for PAVT REM, Modified
- Appendix A: Special Provision for Station Grading
- Appendix A: Special Provision for Subgrade Undercut and Refill
- Appendix A: Special Provision for Utility Structure Adjust
- Appendix A: Special Provision for Bumper Blocks
- Appendix A: Special Provision for Pavement Markings
- Appendix A: Special Provision for Storm Sewer Structures
- Appendix A: Special Provision for Traffic Control

ADVERTISEMENT FOR BID

Northfield Township Hall Parking Lot
Northfield Township
March 12, 2024

Sealed Bids for Northfield Township Hall Parking Lot will be received at the office of the Northfield Township until 2 pm local time, on April 9, 2024, by the office of the Township Clerk located at 8350 Main St, Whitmore Lake, MI 48189. The approximate quantities of major items of work involved are as follows:

500 SY of HMA paving, sidewalk and curb and gutter repairs, storm sewer improvements, restoration and pavement markings.

The issuing Office for the Bidding Documents is the office of the ENGINEER, Orchard, Hiltz, & McCliment, Inc., d/b/a OHM Advisors. Bidding documents may be examined at the following locations after March 12, 2024 at 2:00 PM: OHM Advisors Online Plan Room (Download Fee may apply), ohm-advisors.com; MITN Purchasing Group, Bidnetdirect.com; Northfield Township, 8350 Main St, Whitmore Lake, MI 48189. Neither Owner nor ENGINEER will be responsible for full or partial sets of Bidding Documents, including Addenda if any, obtained from sources other than the Issuing Office. Bidders should direct correspondence to the ENGINEER.

Bid Security in the form of a Certified or Cashier's Check or Bid Bond for a sum no less than 5% of the amount of the Bid will be required with each Bid.

The OWNER reserves the right to accept any Bid, reject any Bid, or waive irregularities in Bids.

No Bid may be withdrawn for a period of sixty (60) calendar days after the scheduled closing time for receipt of the Bids.

No pre-bid meetings are scheduled for this project.

Kathy Manley, Township Clerk
Northfield Township

INSTRUCTIONS TO BIDDERS

1. BIDS

- A. Sealed Bids will be received as per Advertisement for Bids.
- B. Bid Forms shall be submitted only on forms provided by the ENGINEER and shall be of the type specified in the Bid Form.
- C. Bid Forms must be completed legibly in ink or by typewriter. In case of a discrepancy between the unit price and the extended amount, the unit price shown shall govern. Illegibility of any figure or word in the Bid Form may be sufficient cause for rejection of the Bid by the OWNER.
- D. Bid Forms shall be enclosed in sealed envelopes marked with the name of the project and Bidder and shall be delivered to the OWNER at the place specified in the Advertisement for Bids on or before the time specified in the Advertisement for Bids.
- E. Bid Forms shall be made in full conformity with all the conditions set forth in the drawings and in these specifications

2. NAME AND STATUS OF BIDDER

- A. The name and legal status of Bidder, that is, as a corporation, partnership or individual, shall be stated in the Bid Form.
- B. Anyone signing a Bid Form as an agent of another or others must submit with the Bid Form legal evidence of his authority to do so.
- C. The place of residence of each Bidder, or the office address in the case of a firm or company, with county and state, must

be given after his signature. Phone and fax numbers are also required.

3. BID SECURITY

Each Bid must be in the form requested in the Advertisement for Bid. The CONTRACTOR shall complete and sign the Bid Guarantee form (page BG-1). If a Bid Bond is requested, it must be from a Treasury Listed surety company licensed to do business in the state of Michigan in the amount as stated in the Advertisement for Bid, payable to the OWNER as a guarantee on the part of the Bidder that he will, if called upon, enter into the attached Agreement.

4. BONDS

- A. CONTRACTOR will be required to furnish performance and payment bonds each equal to one-hundred percent (100%) of the Contract Sum. The bonds shall be the OWNER's guarantee of the faithful performance and payment of all the CONTRACTOR's obligations under the Agreement. These bonds shall remain in effect for the period as stated in each bond's provisions.
- B. Maintenance and Guarantee Bonds shall be required.

5. INSPECTION OF SITE

- A. Before submitting a Bid Form, each Bidder shall personally inspect the site of the proposed work to arrive at a clear understanding of the conditions under which the work is to be done.
- B. Each Bidder shall be held to have compared the premises with the Bid documents and to have satisfied himself as to conditions of the premises, existing construction and any other conditions

affecting the carrying out of the work before delivery of his Bid Form.

- C. No allowance or extra consideration on behalf of the CONTRACTOR will subsequently be allowed by reason of error or oversight on the part of the CONTRACTOR or on account of interference by the OWNER's or other CONTRACTOR's activities.

6. TIME OF COMPLETION

Time of completion will be as stated in the Agreement.

7. EXPLANATION TO BIDDERS BY ADDENDA

- A. Neither the OWNER nor the ENGINEER will give verbal answers to inquiries regarding the meaning or intent of the Contract Documents prior to award of the Contract. Any verbal statements regarding same by any person prior to the award shall be without legal effect.
- B. Explanations desired by Bidders shall be requested of the ENGINEER in writing and, if explanations are necessary, a reply will be made in the form of an addendum, a copy of which will be forwarded to each Bidder of Record whose work is affected.
- C. Addenda issued to Bidders prior to date of receipt of Bid Forms shall become a part of the Contract Documents, and all Bid Forms shall include the work described in the Addenda.
- D. No inquiry received within four (4) business days of the date fixed for opening of the Bids will be given consideration.
- E. Failure of the ENGINEER to send, or the Bidder to receive, any such interpretations shall not relieve the

Bidder from obligation under his Bid as submitted.

- F. Bidder of Record is defined as an individual, partnership or corporation having purchased a set of Bid Documents from the ENGINEER.

8. EXPERIENCE AND FINANCIAL STATEMENT

- A. It is the intention of the OWNER to award the Contract to a contractor fully capable, both financially and as regards to experience to perform and complete the work in a satisfactory manner. Each Bidder must complete the Statement of Qualifications, which follows the Bid Form. If required by the OWNER, each Bidder under consideration may be required to submit additional evidence of qualifications.
- B. Each Bidder under consideration must be able to demonstrate that the Bidder has successfully completed projects of a similar nature and scope within the last two years.

9. SUBCONTRACTORS

Bidder shall submit to OWNER a list of all subcontractors and other persons and organizations (including those who are to furnish the principal items of material and equipment) proposed for those portions of work as to which such identification is so required. If requested by the OWNER, the apparent successful Bidder and any other Bidder so requested, will, within ten (10) days after the day of Bid opening, submit a Statement of Qualifications with pertinent information as to similar projects and other evidence of qualification for each such subcontractor, person and organization if requested by the OWNER. If the OWNER or ENGINEER, after due investigation, has reasonable objection to any proposed subcontractor, other person or organization, OWNER may request the apparent successful Bidder to submit an acceptable

substitute without an increase in Bid price. If the apparent successful Bidder declines to make any such substitutions, the Contract shall not be awarded to such Bidder, but his declining to make any such substitution will not constitute grounds for sacrificing his Bid Security. Any subcontractor, other person or organization so listed and to whom the OWNER or ENGINEER does not make written objection prior to signing of the Agreement will be deemed acceptable to the OWNER and ENGINEER.

10. AWARD OF CONTRACT

The OWNER reserves the right to accept any Bid, to reject any or all Bids, and to waive defects or irregularities in any Bid for any reason or no reason at all. The OWNER also reserves the right to award some, none, or all of the Contract.

11. LIQUIDATED DAMAGES/INCENTIVES

- A. If the CONTRACTOR fails to complete all the work within the time stipulated, he will be assessed liquidated damages as set forth in the Agreement.
- B. If set forth in the Agreement, incentives will be paid by OWNER to CONTRACTOR at the rate specified in the Agreement, when the work is completed prior to the time specified in the Agreement.

12. TAXES

The Bidder shall include in the base Bid and shall pay all applicable federal, state and local taxes of whatever character and description.

End of Section

SUPPLEMENTAL INSTRUCTIONS TO BIDDERS

These Supplemental Instructions to Bidders (SIB) amend or supplement the Instructions to Bidders. All provisions that are not so amended or supplemented remain in full force and effect.

A. Time of Completion & Construction Schedule

Prior to the execution of the Contract, the CONTRACTOR shall submit an outline of his proposed order of work and indicate dates for completing the major items of work. Major items shall be considered to be installation of storm system, removal of pavement, station grading, paving, and surface restoration. This schedule, when approved by the OWNER, shall become part of the Contract.

A pre-construction meeting shall be arranged prior to the start of work. The CONTRACTOR shall bring a tentative schedule to the pre-construction meeting. At this time, all Contract requirements shall be reviewed.

It is anticipated that construction will begin on May 6, 2024. The CONTRACTOR shall complete the proposed work, including final tests thereof, in order to have the drive, parking lot, sidewalk, path, storm system, and raised lawn finished as of the substantial completion date. Final cleanup and restoration shall be finished by the project completion date, unless otherwise directed in writing by the OWNER or its ENGINEER.

Summary of anticipated dates:

Contract Award	4/9/2024
Notice to Proceed	5/10/2024
Construction Start Date	10 Days after award
Substantial Completion Date.....	8/30/2024
Project Completion.....	10/15/2024

All requests for extensions of time shall be submitted in writing in accordance with Section 15 of the General Conditions. Such requests shall:

1. Detail the reason for the request.
2. Provide a realistic revised completion date.
3. Indicate any other areas that may be impacted by such an extension.

The CONTRACTOR shall request a deadline extension as soon as it has become apparent the completion date is unreasonable. In no case will a request be considered if it is submitted after the originally required completion date has passed.

B. Permits

The following permits will be required for project construction. The CONTRACTOR is required to comply with all terms and conditions of the permit as incidental to the unit prices bid and no extra compensation will be allowed.

a. Permitting Agency: Washtenaw County Road Commission ROW Permit

Contact at Agency: Gary Streight

Phone number: (734) 761-1500

Permit Fee: TBD

Bond Amount (if applicable): TBD

Date of Application: _____

Person Responsible for Acquiring the Permit: Contractor

Date Permit issued if already in hand: _____

Application has been made by the Engineer for the permits identified above. Unless otherwise indicated, the CONTRACTOR must secure the permits prior to the start of construction and shall be responsible for all associated fees, deposits, bonds, proof of insurance, etc. The Contractor shall also be responsible for arranging for inspection by the governing agencies. Cost of permits and bonds paid under Permit Allowance.

Work cannot proceed until all permits are obtained.

b. Permitting Agency: Washtenaw County Drain Commission-SESC

Contact at Agency: _____

Phone number: _____

Permit Fee: TBD

Bond Amount (if applicable): TBD

Date of Application: _____

Person Responsible for Acquiring the Permit: Contractor

Date Permit issued if already in hand: _____

Work cannot proceed until all permits are obtained.

INSURANCE SPECIFICATIONS

1. LIABILITY OF CONTRACTOR

The Contractor shall take all responsibility for the work and shall provide barricades, watchmen and lights, and take all precautions for preventing injuries to persons and property on or about the work; shall bear all losses resulting to him on account of the amount or character of the work or because the nature of the ground in which the work is done is different from what was estimated or expected, or on account of weather, floods, elements or other cause; and shall assume defense of, indemnify and save harmless the party of the first part and its individual officers and agents from all claims relating to labor, equipment and materials furnished for the work, inventions, patents and patent rights used in doing the work, also to injuries to any person or property received or sustained by or from the CONTRACTOR, his agents or employees.

The mention of any specific duty or liability of the CONTRACTOR in any part of the specifications shall not be construed as a limitation or restriction upon any general liability or duty imposed upon the CONTRACTOR by the specifications.

INDEMNIFICATION - HOLD HARMLESS AGREEMENT

The CONTRACTOR agrees to indemnify, defend, and save harmless the OWNER and ENGINEER, their consultants, agents, and employees, from and against all loss or expense (including costs and attorney's fees) by reason of liability imposed by law upon the OWNER and ENGINEER, their consultants, agents, and employees for damages to property and for damages because of bodily injury, including death at any time resulting therefrom, arising out of or in consequence of the performance of this work, whether such injuries to persons or damage to property is due, or claimed to be due, to the negligence of the CONTRACTOR, his subcontractors, the OWNER, the ENGINEER, and their consultants, agents, and employees, except only such injury or damage as shall have been occasioned by the sole negligence of the

OWNER, the ENGINEER, and their agents and/or consultants.

COMPOSITION OF THE CONTRACTOR

If the CONTRACTOR hereunder is comprised of more than one legal entity, each such entity shall be jointly and severally liable hereunder.

2. INSURANCE

2.1. Insurance Required of the CONTRACTOR:

Prior to commencement of work, the CONTRACTOR shall purchase and maintain during the term of the project such insurance as will protect him, the OWNER(s), and Orchard, Hiltz & McCliment, Inc., Consulting Engineers, from claims arising out of the work described in this Contract and performed by the CONTRACTOR, subcontractor(s) or sub-subcontractor(s) consisting of:

2.1.1. Workers' Compensation Insurance including Employer's Liability to cover employee injuries or disease compensable under the Workers' Compensation Statutes of the states in which work is conducted under this Contract; disability benefit laws, if any; or Federal compensation acts such as U.S. Longshoremen or Harbor Workers', Maritime Employment, or Railroad Compensation Act(s), if applicable. Self-insurance plans approved by the regulatory authorities in the state in which work on this project is performed are acceptable.

2.1.2. A Comprehensive General Liability policy to cover bodily injury to persons other than employees and for damage to tangible property including loss of use thereof, including the following exposures:

- A. All premises and operations.
- B. Explosion, collapse and underground damage.

- C. Contractor's Protective coverage for independent contractors or subcontractors employed by him.
- D. Contractual Liability for the obligation assumed in the Indemnification or Hold Harmless agreement found under Part I of this Section.
- E. The usual Personal Injury Liability endorsement with no exclusions pertaining to employment.
- F. Products and Completed Operations coverage. This coverage shall extend through the contract guarantee period.

2.1.3. A Comprehensive Automobile Liability policy to cover bodily injury and property damage arising out of the ownership, maintenance or use of any motor vehicle, including owned, non-owned and hired vehicles. In light of the standard policy provisions concerning (a) loading and unloading, and b) definitions pertaining to motor vehicles licensed for road use vs. unlicensed or self-propelled construction equipment, it is strongly recommended that Comprehensive General Liability and Comprehensive Auto Liability be written by the same insurance carrier, though not necessarily in one policy.

2.1.4. CONTRACTOR will purchase for the OWNER an Owner's Protective Liability policy to protect the OWNER; the ENGINEER (Orchard, Hiltz & McCliment, Inc.); their consultants, agents, employees and such public corporations in whose jurisdiction the work is located for their contingent liability for work performed by the CONTRACTOR, the subcontractor(s) or the sub-subcontractor(s) under this Contract.

2.1.5. CONTRACTOR shall purchase a Builder's Risk-Installation Floater in a form acceptable to the OWNER covering property of the project for the full cost of replacement as of the time of any loss which shall include, as named insureds, (a) the CONTRACTOR, (b)

all subcontractors, (c) all sub-subcontractors, (d) the OWNER, and Orchard, Hiltz & McCliment, Inc., Consulting Engineers, as their respective interests may prove to be at the time of loss, covering insurable property which is the subject of this Contract, whether in place, stored at the job site, stored elsewhere, or in transit at the risk of the insured(s). Coverage shall be effected on an "All Risk" form, including but not limited to the perils of fire, wind, collapse, vandalism, theft and earthquake, with exclusions normal to the cover. The CONTRACTOR may arrange for such deductibles as he deems to be within his ability to self-assume, but he will be held solely responsible for the amount of such deductible and for any co-insurance penalties. Any insured loss shall be adjusted with the OWNER and CONTRACTOR and paid to the OWNER and CONTRACTOR as Trustee for the other insureds.

2.1.6. Umbrella or Excess Liability

The OWNER or its representative may, for certain projects, require limits higher than those stated in paragraph. 2.2 that follows. CONTRACTOR is granted the option of arranging coverage under a single policy for the full limit required or by a combination of underlying policies with the balance provided by an Excess or Umbrella Liability policy equal to the total limit(s) requested. Umbrella or Excess policy wording shall be at least as broad as the primary or underlying policy(ies) and shall apply both to the CONTRACTOR's general liability and to his automobile liability insurance.

2.1.7. Railroad Protective Liability

Where such an exposure exists, the CONTRACTOR will provide coverage in the use of each railroad company having jurisdiction over rights-of-way across which work under the Contract is to be performed. The form of policy and limits

of liability shall be determined by the railroad company(ies) involved.

2.2.6. Umbrella or Excess Liability

\$2,000,000

2.2. Limits of Liability

The required limits of liability for insurance coverages requested in Section 2.1 shall be not less than the following:

2.2.1. Worker's Compensation

Coverage A Compensation	Statutory
Coverage B Employer's Liability	\$100,000

2.2.2. Comprehensive General Liability

Bodily Injury - Each Occurrence	\$500,000
Bodily Injury - Aggregate (Completed Operations)	\$500,000
Property Damage - Each Occurrence	\$100,000
Property Damage - Aggregate	\$500,000
or combined single limit	\$1,000,000

2.2.3. Comprehensive Automobile Liability

Bodily Injury	\$500,000
Property Damage	\$200,000
or combined single limit	\$1,000,000

2.2.4. Owner's Protective

Bodily Injury- Each Occurrence	\$1,000,000
Property Damage- Each Occurrence	\$250,000
Property Damage- Aggregate	\$500,000
or combined single limit	\$1,500,000

2.2.5. Builder's Risk-Installation Floater

Cost to replace at time of loss

2.3. Insurance - Other Requirements

2.3.1. Notice of Cancellation or Intent Not to Renew

Policies will be endorsed to provide that at least thirty (30) days written notice shall be given to the OWNER and the ENGINEER of cancellation or of intent not to renew.

2.3.2. Evidence of Coverage

Prior to the commencement of work, the CONTRACTOR shall furnish to the OWNER, Certificates of Insurance in force on the Owner's Form of Certificate provided. Other forms of certificate are acceptable only if (1) they include all items prescribed in the Owner's Form of Certificate, including agreement to cancellation provisions outlined in Paragraph 2.3.1 above, and (2) they have the written approval of the OWNER and ENGINEER. The OWNER reserves the right to request complete copies of the policies if deemed necessary to ascertain details of coverage not provided by the certificates. Such policy copies shall be "Originally Signed Copies," and so designated.

A. Insurance Required for the CONTRACTOR

- i. Workers' Compensation and Employers' Liability Comprehensive General Liability, including:
 - a. All premises and operations.
 - b. Explosion, collapse, and underground damage.
 - c. Contractors' Protective.
 - d. Contractual Liability for obligations assumed in the Indemnification-Hold Harmless agreement of this contract.
 - e. Personal Injury Liability.
 - f. Products and Completed Operations.
- ii. Comprehensive Automobile Liability, including owned, non-owned, and hired vehicles.
- iii. Umbrella or Excess Liability.

B. Insurance Required for the OWNER

Owners' Protective Liability which names as insured(s) the OWNER; the ENGINEER, Orchard, Hiltz & McCliment, Inc.; their consultants, agents, employees and such public corporations in whose jurisdiction the work is located.

C. Insurance Required for the CONTRACTOR and the OWNER

Builders Risk-Installation Floater which names as insured(s) the OWNER; the ENGINEER, Orchard, Hiltz & McCliment, Inc.; their consultants, agents and employees; the CONTRACTOR and all subcontractors.

2.3.3. Qualification of Insurers

In order to determine the financial strength and reputation of insurance carriers, all companies providing coverages required shall be licensed or approved by the Office of Financial and Insurance Services of the State of Michigan. The company shall also have a financial rating not lower than X and a policyholder's service rating no lower than A as listed in A.M. Best's Key Rating Guide, current edition. Companies with ratings lower than A:X will be acceptable only upon the written consent of the OWNER

End of Section

BID FORM

Northfield Township Hall Parking Lot
Northfield Township

THIS BID IS SUBMITTED TO:
Northfield Township
8350 Main St
Whitmore Lake, MI 48189

The undersigned Bidder proposes and agrees, if this Bid is accepted, to enter into an Agreement with OWNER in the form included in the Bidding Documents to perform all Work as specified or indicated in the Bidding Documents for the prices and within the times indicated in this Bid and in accordance with the other terms and conditions of the Bidding Documents.

Bidder accepts all of the terms and conditions of the Advertisement to Bid, Instructions to Bidders and Supplemental Instructions to Bidders.

In submitting this Bid, Bidder represents, as set forth in the Agreement, that:

- A. Bidder has examined and carefully studied the Bidding Documents, the other related data identified in the Bidding Documents, and the following Addenda, receipt of all which is hereby acknowledged.

Addenda No.	Addenda Date	Signature
_____	_____	_____
_____	_____	_____
_____	_____	_____

- B. Bidder has visited the site and become familiar with and is satisfied as to the general, local and Site conditions that may affect cost, progress, and performance of the Work.
- C. Bidder is familiar with and is satisfied as to all federal, state and local Laws and Regulations that may affect cost, progress and performance of the Work.
- D. Bidder has carefully studied all: (1) reports of explorations and tests of subsurface conditions at or contiguous to the site and all drawings of physical conditions in or relating to existing surface or subsurface structures at or contiguous to the site (except underground facilities) which have been identified in the Supplemental Instructions to Bidders, and (2) reports and drawings of a hazardous environmental condition, if any, which has been identified in the Supplemental Instructions to Bidders.
- E. Bidder has obtained and carefully studied (or assumes responsibility for having done so) all additional or supplementary examinations, investigations, explorations, tests, studies and data concerning conditions (surface, subsurface and underground facilities) at or contiguous to the site which may affect cost, progress, or performance of the Work or which relate to any aspect of the means, methods, techniques, sequences, and procedures of construction to be

employed by Bidder, including applying the specific means, methods, techniques, sequences, and procedures of construction expressly required by the Bidding Documents to be employed by Bidder, and safety precautions and programs incident thereto.

- F. Bidder does not consider that any further examinations, investigations, exploration, tests, studies, or data are necessary for the determination of this Bid for performance of the Work at the price(s) bid and within the times and in accordance with the other terms and conditions of the Bidding Documents.
- G. Bidder is aware of the general nature of work to be performed by OWNER and others at the Site that relates to the Work as indicated in the Bidding Documents.
- H. Bidder has correlated the information known to Bidder, information and observations obtained from visits to the Site, reports and drawings identified in the Bidding Documents, and all additional examinations, investigations, explorations, tests, studies, and data with the Bidding Documents.
- I. Bidder has given ENGINEER written notice of all conflicts, errors, ambiguities, or discrepancies that Bidder has discovered in the Bidding Documents, and the written resolution thereof by ENGINEER is acceptable to Bidder.
- J. The Bidding Documents are generally sufficient to indicate and convey understanding of all terms and conditions for the performance of the Work for which this Bid is submitted.

Bidder further represents that this Bid is genuine and not made in the interest of or on behalf of any undisclosed individual or entity and is not submitted in conformity with any agreement or rules of any group, association, organization or corporation; Bidder has not directly or indirectly induced or solicited any other Bidder to submit a false or sham Bid; Bidder has not solicited or induced any individual or entity to refrain from bidding; and Bidder has not sought by collusion to obtain for itself any advantage over any other Bidder or over OWNER.

Bidder will complete the Work in accordance with the Contract Documents for the following price(s):

**BID FORM for
Northfield Township Hall Parking Lot
Northfield Township, State of Michigan
OHM Job Number 0151-23-0030**

Item	Description	Estimated Quantity	Unit Price	Amount
1	Permit Fees	1.00 Dlr	\$ _____	\$ _____
2	Mobilization, Max 10%	1.00 LSUM	\$ _____	\$ _____
3	Curb and Gutter, Rem	300.00 Ft	\$ _____	\$ _____
4	Sidewalk, Rem	138.00 Syd	\$ _____	\$ _____
5	Pavt, Rem, Modified	2730.00 Syd	\$ _____	\$ _____
6	Rem and reset bumper blocks	42.00 Ea	\$ _____	\$ _____
7	Dr Str Flattop, Rem and Replace, 72 in	1.00 LSUM	\$ _____	\$ _____
8	Ditch Cleanout	1.00 Sta	\$ _____	\$ _____
9	Station Grading	2841.00 Syd	\$ _____	\$ _____
10	Subgrade Undercutting and Refill, 21AA	10.00 Cyd	\$ _____	\$ _____
11	Erosion Control, Inlet Protection, Fabric Drop	9.00 Ea	\$ _____	\$ _____
12	Aggregate Base	14.00 Ton	\$ _____	\$ _____
13	Dr Structure, Adj, Add Depth	2.00 Ft	\$ _____	\$ _____
14	Dr Str Cover, Low Profile	1.00 Ea	\$ _____	\$ _____
15	Structure Cover, Adj, Case 1, Conc Collars	8.00 Ea	\$ _____	\$ _____
16	Cold Milling HMA Surface	2924.00 Syd	\$ _____	\$ _____
17	HMA, 3C	296.00 Ton	\$ _____	\$ _____
18	HMA, 5EL	613.00 Ton	\$ _____	\$ _____
19	Pavt Repr, Nonreinf Conc, 8 inch	11.00 Syd	\$ _____	\$ _____
20	Resealing Trans Joints with Hot-Poured Rubber	656.00 Ft	\$ _____	\$ _____
21	Resealing Longit Joints with Hot-Poured Rubber	740.00 Ft	\$ _____	\$ _____
22	Curb and Gutter, Conc, Det F4	300.00 Ft	\$ _____	\$ _____
23	Sidewalk, Conc, 4 inch	561.00 Sft	\$ _____	\$ _____

**BID FORM for
Northfield Township Hall Parking Lot
Northfield Township, State of Michigan
OHM Job Number 0151-23-0030**

Item	Description	Estimated Quantity	Unit Price	Amount
24	Curb Ramp, Conc, 4 inch	50.00 Sft	\$ _____	\$ _____
25	Sidewalk, Conc, Thickened Edge	392.00 Sft	\$ _____	\$ _____
26	Sign, Type III, Rem	4.00 Ea	\$ _____	\$ _____
27	Sign, Type IIIA	6.00 Sft	\$ _____	\$ _____
28	Pavement Markings	1.00 LSUM	\$ _____	\$ _____
29	Traffic Control	1.00 LSUM	\$ _____	\$ _____
30	Slope Restoration, Non-Freeway, Type B	409.00 Syd	\$ _____	\$ _____
Total Bid Amount (ITEM 1-30 incl.):				\$ _____

Bidder acknowledges that estimated quantities are not guaranteed, and are solely for the purpose of comparison of Bids, and final payment for all unit price bid items will be based on actual quantities constructed in accordance with the Contract Documents.

Bidder agrees that the Work will be Substantially Complete on or before August 30, 2024, and completed and ready for final payment in accordance with the General Conditions on or before October 15, 2024.

Bidder accepts the provisions of the Agreement as to liquidated damages in the event of failure to complete the Work within the times specified above, which shall be stated in the Agreement.

The following documents are attached to and made a condition of this Bid:

- Bid Guarantee (circle one): Certified or Cashier's Check or Bid Bond
- Statement of Qualifications
- Subcontractor Listing
- Legal Status of Bidder

SUBMITTED on _____, 20 _____

State Contractor License No. _____ . (If applicable)

If Bidder is:

An Individual

Name (typed or printed): _____

By: _____ (SEAL)
(Individual's signature)

Doing business as: _____

Business address: _____

Phone No.: _____ FAX No.: _____

A Partnership

Partnership Name: _____ (SEAL)

By: _____
(Signature of general partner – attach evidence of authority to sign)

Name (typed or printed): _____

Business address: _____

Phone No.: _____ FAX No.: _____

A Corporation

Corporation Name: _____ (SEAL)

State of Incorporation: _____

Type (General Business, Professional, Service, Limited Liability): _____

By: _____
(Signature – attach evidence of authority to sign)

Name (typed or printed): _____

Title: _____

Attest: _____ (CORPORATE SEAL)
(Signature of Corporate Secretary)

Business address: _____

Phone No.: _____ FAX No.: _____

Date of Qualification to do business is: _____

A Joint Venture

Joint Venture Name: _____ (SEAL)

By: _____
(Signature of joint venture partner – attach evidence of authority to sign)

Name (typed or printed): _____

Title:

Business address: _____

Phone No.: _____ FAX No.: _____

Joint Venture Name: _____ (SEAL)

By: _____
(Signature of joint venture partner – attach evidence of authority to sign)

Name (typed or printed): _____

Title:

Business address: _____

Phone No.: _____ FAX No.: _____

Phone and FAX Number, and Address for receipt of official communications.

(Each joint venturer must sign. The manner of signing for each individual, partnership, and corporation that is a party to the joint venture should be in the manner indicated above).

BID GUARANTEE

The undersigned attaches bid security in the form of a BID BOND / CERTIFIED CHECK / CASHIER'S CHECK (Circle one) in the amount of _____

Dollars (\$_____).

The undersigned agrees, if awarded the Contract, to deliver the executed Agreement and bonds and furnish evidence of insurance within fourteen (14) business days after the date of the Notice of Award. And to complete the proposed work within the time specified in the Bid Form.

If the Bid is accepted by the OWNER, and the undersigned shall fail to enter into the Agreement as aforesaid and to furnish the required surety bonds within fourteen (14) business days after Notice of Award, the Bid Bond in the amount of \$_____ accompanying this Bid shall be considered due and payable to the OWNER.

If the undersigned enters into the Agreement in accordance with this Bid or if his Bid is rejected, then the accompanying Bid Guarantee shall be voided.

In submitting this Bid, it is understood that the right is reserved by the OWNER to reject any or all bids, to waive irregularities and/or formalities and, in general, to make award in any manner deemed by it, in its sole discretion, to be in the best interest of the OWNER.

SIGNED AND SEALED THIS _____ DAY OF _____, 20 _____

Authorized Signature of Bidder: _____

(TITLE) _____

(SEAL)

BID BOND

BIDDER (Name and Address):

SURETY (Name and Address of Principal Place of Business):

OWNER (Name and Address):

Northfield Township
8350 Main St
Whitmore Lake, MI 48189

BID

BID DUE DATE: April 9, 2024

PROJECT (Brief Description Including Location):

500 SY of HMA paving, sidewalk and curb and gutter repairs, storm sewer improvements, restoration and pavement markings.

1. Bidder and Surety, jointly and severally, bind themselves, their heirs, executors, administrators, successors and assigns to pay to OWNER upon default of Bidder the penal sum set forth on the face of this Bond.
2. Default of Bidder shall occur upon the failure of Bidder to deliver within the time required by the Bidding Documents (or any extension thereof agreed to in writing by OWNER) the executed Agreement required by the Bidding Documents and any performance and payment bonds required by the Bidding Document.
3. This obligation shall be null and void if:
 - 3.1. OWNER accepts Bidder's Bid and Bidder delivers within the time required by the Bidding Documents (or any extension thereof agreed to in writing by OWNER) the executed Agreement required by the Bidding Documents and any performance and payment Bonds required by the Bidding Documents, or
 - 3.2. All Bids are rejected by OWNER, or
 - 3.3. OWNER fails to issue a Notice of Award to Bidder within the time specified in the Bidding Documents (or any extension thereof agreed to in writing by Bidder and, if applicable, consented to by Surety when required by paragraph 5 hereof).
4. Payment under this Bond will be due and payable upon default by Bidder and within 30 calendar days after receipt by Bidder and Surety of written notice of default from OWNER, which notice will be given with reasonable promptness, identifying this Bond and the Project and including a statement of the amount due.
5. Surety waives notice of and any and all defenses based on or arising out of any time extension to issue Notice of Award agreed to in writing by OWNER and Bidder, provided that the total time of issuing Notice of Award including extensions shall not in the aggregate exceed 120 days from Bid due date without Surety's written consent.
6. No suit or action shall be commenced under this Bond prior to 30 calendar days after the notice of default required in paragraph 4 above is received by Bidder and Surety and in no case later than one year after Bid due date.
7. Any suit or action under this Bond shall be commenced only in a court of competent jurisdiction located in the state in which the Project is located.
8. Notices required hereunder shall be in writing and sent to Bidder and Surety at their respective addresses shown on the face of this Bond. Such notices may be sent by personal delivery, commercial courier or by United States Registered or Certified Mail, return receipt requested, postage pre-paid, and shall be deemed to be effective upon receipt by the party concerned.
9. Surety shall cause to be attached to this Bond a current and effective Power of Attorney evidencing the authority of the officer, agent or representative who executed this Bond on behalf of Surety to execute, seal and deliver such Bond and bind the Surety thereby.
10. This Bond is intended to conform to all applicable statutory requirements. Any applicable requirement of any applicable statute that has been omitted from this Bond shall be deemed to be included herein as if set forth at length. If any provision of this Bond conflicts with any applicable statute, then the provision of said statute shall govern and the remainder of this Bond that is not in conflict therewith shall continue in full force and effect.
11. The term "Bid" as used herein includes a Bid, offer or proposal as applicable.

End of Section

STATEMENT OF QUALIFICATIONS

Bidder must answer all questions. If more space is needed to complete a question, attach a separate sheet. Bidder may submit any additional information.

Name: _____

Address: _____ Phone: _____

Number of years operating under your present name: _____

Bonding Capacity: _____

Bonding Company: _____ Phone: _____

Prequalified by MDOT to bid on projects of this magnitude and type of work

(circle one) YES NO Prequalification Number: _____

General nature of work performed by your company: _____

Background and experience of the principal members of your organization including officers:

Major equipment available for this contract: _____

CURRENT PROJECTS:

	Project	Project	Project
Name:	_____	_____	_____
Owner:	_____	_____	_____
Contact Person:	_____	_____	_____
Phone:	_____	_____	_____
Contract Amount:	_____	_____	_____
Completion Date:	_____	_____	_____
% Complete:	_____	_____	_____

COMPLETED PROJECTS:

	Project	Project	Project
Name:	_____	_____	_____
Owner:	_____	_____	_____
Contact Person:	_____	_____	_____
Phone:	_____	_____	_____
Contract Amount:	_____	_____	_____
Date Completed:	_____	_____	_____

Additional information that may be pertinent to demonstrate your ability to complete this project.

Has your company defaulted on a contract? _____

If yes, where and why? _____

I hereby certify that the above answers are correct and true.

By: _____
Name

Signature

Title

Number of additional sheets attached: _____

SUBCONTRACTOR LISTING

Bidder submits to use the following subcontractors for performance of the work in accordance with Article 9 of the Instructions to Bidders.

Note to Bidder: List all work you propose to sublet on this Contract. Include each subcontractors name, address, phone, fax and e-mail address. Also include a description of work to be performed by subcontractor. For example: restoration, landscaping, lighting, signage, bore and jack, etc. List approximate dollar value of the subcontract.

NAME, ADDRESS & PHONE NO. OF SUBCONTRACTOR	DESCRIPTION OF WORK	APPROXIMATE DOLLAR VALUE OF SUBCONTRACT
_____ _____ _____ Phone: _____ FAX: _____ E-mail _____	_____ _____ _____	\$ _____
_____ _____ _____ Phone: _____ FAX: _____ E-mail _____	_____ _____ _____	\$ _____

_____ \$ _____

Phone: _____

FAX: _____

E-mail _____

_____ \$ _____

Phone: _____

FAX: _____

E-mail _____

_____ \$ _____

Phone: _____

FAX: _____

E-mail _____

IRAN LINKED BUSINESS CERTIFICATION

Pursuant to Michigan Public Act 517 of 2012, any Bidder that submits a bid on a request for proposal with Northfield Township shall certify that Bidder is not an Iran linked business. An Iran linked business is not eligible to submit a bid on a request for proposal with Northfield Township. See attached definitions regarding this certification.

The undersigned Bidder does hereby certify, pursuant to Michigan Public Act 517 of 2012, that:

Bidder is not a person engaging in investment activities in the energy sector of Iran, including a person that provides oil or liquefied natural gas tankers, or products used to construct or maintain pipelines used to transport oil or liquefied natural gas, for the energy sector of Iran, or

Bidder is not a financial institution that extends credit to another person if that person will use the credit to engage in investment activities in the energy sector of Iran.

Date: _____

By: _____

Its: _____

Subscribed and sworn to before me, a Notary Public on this _____ day of _____, .

Notary Public _____

_____ County, Michigan

My Commission Expires: _____

DEFINITIONS

- (A) “Energy sector of Iran” means activities to develop petroleum or natural gas resources or nuclear power in Iran.
- (B) “Investment” means 1 or more of the following:
- i. A commitment or contribution of funds or property.
 - ii. A loan or other extension of credit.
 - iii. The entry into or renewal of a contract for goods or services.
- (C) “Investment activity” means 1 or more of the following:
- i. A person who has an investment of \$20,000,000.00 or more in the energy sector of Iran.
 - ii. A financial institution that exceeds \$20,000,000.00 or more in credit to another person, for 45 days or more, if that person will use the credit for investment in the energy sector of Iran.
- (D) “Iran” means any agency or instrumentality of Iran.
- (E) “Iran linked business” means either of the following:
- i. A person engaging in investment activities in the energy sector of Iran, including a person that provides oil or liquefied natural gas tankers or products used to construct or maintain pipelines used to transport oil or liquefied natural gas for the energy sector of Iran.
 - ii. A financial institution that extends credit to another person, if that person will use the credit to engage in investment activities in the energy sector of Iran.
- (F) “Person” means any of the following:
- i. An individual, corporation, company, limited liability company, business association, partnership, society, trust, or any other nongovernmental entity, organization, or group.
 - ii. Any governmental entity or instrumentality of a government, including a multilateral development institution, as defined in section 1701(c) (3) of the international financial institutional act, 22 USC 262r(c) (3).
 - iii. Any successor, subunit, parent company, or subsidiary of, or company under common ownership or control with, any entity described in subparagraph (i) or (ii).
- (G) “Public entity” means this state or an agency or authority of this state, school district, community college district, intermediate school district, city, village, township, county, public authority, or public airport authority.

AGREEMENT

This AGREEMENT is by and between Northfield Township (hereinafter called OWNER) and _____ (hereinafter called CONTRACTOR).

ARTICLE 1 WORK

1.01 CONTRACTOR shall complete all Work as specified or indicated in the Contract Documents. The Work is generally described as follows:

500 SY of HMA paving, sidewalk and curb and gutter repairs, storm sewer improvements, restoration and pavement markings.

ARTICLE 2 THE PROJECT

2.01 The Project for which the Work under the Contract Documents may be the whole or only a part is generally described as follows:

Northfield Township Hall Parking Lot

ARTICLE 3 ENGINEER

3.01 The Project has been designed by Orchard Hiltz & McCliment, Inc. who is hereinafter called ENGINEER and who is to act as OWNER's representative, assume all duties and responsibilities, and have the rights and authority assigned to ENGINEER in the Contract Documents in connection with the completion of the Work in accordance with the Contract Documents.

ARTICLE 4 CONTRACT TIMES

4.01 Time is of the Essence

A. All time limits for Milestones, if any, Substantial Completion, and completion and readiness for final payment as stated in the Contract Documents are of the essence of the Contract.

4.02 Dates for Substantial Completion and Final Payment

A. The Work will be substantially completed on or before August 30, 2024, and completed and ready for final payment on or before October 15, 2024.

4.03 Liquidated Damages

A. CONTRACTOR and OWNER recognize that time is of the essence of this Agreement and that OWNER will suffer financial loss if the Work is not completed within the times specified in paragraph 4.02 above, plus any extensions thereof allowed in accordance with Article 15 of the General Conditions. The parties also recognize the delays, expense, and difficulties involved in proving in a legal or arbitration proceeding the actual loss suffered by OWNER if the Work is not completed on time. Accordingly, instead of requiring any such proof, OWNER and CONTRACTOR agree that as liquidated damages for delay (but not as a penalty), CONTRACTOR shall pay OWNER \$800/day for each day that expires after the time specified in paragraph 4.02 for Substantial Completion until the Work is substantially complete. After Substantial Completion, if CONTRACTOR shall neglect, refuse, or fail to complete the remaining Work within the Contract Time or any proper extension thereof granted by OWNER, CONTRACTOR shall pay OWNER \$800/day for each day that expires after the time specified in paragraph 4.02 for completion and readiness for final payment until the Work is completed and ready for final payment.

ARTICLE 5 CONTRACT PRICE

5.01 OWNER shall pay CONTRACTOR for completion of the Work in accordance with the Contract Documents an amount in current funds equal to the sum of the amounts determined pursuant to paragraph 5.01.A below:

- A. For all Unit Price Work, an amount equal to the sum of the established unit price for each separately identified item of Unit Price Work multiplied by the measured quantity of that item as indicated in the Bid Form (Bid Form to be inserted here at the time the Agreement is to be signed.):

As provided in Article 13 of the General Conditions, estimated quantities are not guaranteed, and determinations of actual quantities and classifications are to be made by ENGINEER as provided in Article 23 of the General Conditions.

ARTICLE 6 PAYMENT PROCEDURES

6.01 Submittal and Processing of Payments

CONTRACTOR shall be paid in accordance with Article 14 of the General Conditions.

ARTICLE 7 CONTRACTOR'S REPRESENTATIONS

7.01 In order to induce OWNER to enter into this Agreement CONTRACTOR makes the following representations:

CONTRACTOR has examined and carefully studied the Contract Documents and the other related data identified in the Bidding Documents.

CONTRACTOR has visited the site and become familiar with and is satisfied as to the general, local and site conditions that may affect cost, progress, and performance of the Work.

CONTRACTOR is familiar with and is satisfied as to all federal, state, and local Laws and Regulations that may affect cost, progress, and performance of the Work.

CONTRACTOR has carefully studied all: (1) reports of explorations and tests of subsurface conditions at or contiguous to the site and all drawings of physical conditions in or relating to existing surface or subsurface structures at or contiguous to the site (except underground facilities) which have been identified in the Supplemental Instructions to Bidders and (2) reports and drawings of a hazardous environmental condition, if any, at the site which has been identified in the Supplemental Instructions to Bidders.

CONTRACTOR has obtained and carefully studied (or assumes responsibility for having done so) all additional or supplementary examinations, investigations, explorations, tests, studies, and data concerning conditions (surface, subsurface, and underground facilities) at or contiguous to the site which may affect cost, progress, or performance of the Work or which relate to any aspect of the means, methods, techniques, sequences and procedures of construction to be employed by CONTRACTOR, including applying the specific means, methods, techniques, sequences, and procedures of construction, if any, expressly required by the Contract Documents to be employed by CONTRACTOR, and safety precautions and programs incident thereto.

CONTRACTOR does not consider that any further examinations, investigations, exploration, tests, studies, or data are necessary for the performance of the Work at the Contract Price, within the Contract Times, and in accordance with the other terms and conditions of the Contract Documents.

CONTRACTOR is aware of the general nature of work to be performed by OWNER and others at the Site that relates to the Work as indicated in the Contract Documents.

CONTRACTOR has correlated the information known to CONTRACTOR, information and observations obtained from visits to the site, reports and drawings identified in the Contract Documents, and all additional examinations, investigations, explorations, tests, studies, and data with the Contract Documents.

CONTRACTOR has given ENGINEER written notice of all conflicts, errors, ambiguities, or discrepancies that CONTRACTOR has discovered in the Contract Documents, and the written resolution thereof by ENGINEER is acceptable to CONTRACTOR.

The Contract Documents are generally sufficient to indicate and convey understanding of all terms and conditions for performance and furnishing of the Work.

ARTICLE 8 CONTRACT DOCUMENTS

8.01 Contents

A. The Contract Documents consist of the following:

1. This Agreement;
2. Performance Bond;
3. Payment Bond;
4. Maintenance and Guarantee Bond;
5. General Conditions;
6. General Specifications;
7. Technical Specifications as listed in the table of contents of the Project Manual;
8. Appendices (excluding geotechnical reports);
9. Drawings consisting of a cover sheet and sheets numbered 1 through 9, inclusive, with each sheet (excluding standard details) bearing the following general title:
Northfield Township Hall Parking Lot;
10. Addenda (numbers ____ to ____, inclusive);
11. Exhibits to the Agreement (enumerated as follows):
 - a. Documentation submitted by CONTRACTOR prior to Notice of Award (pages ___ to ___, inclusive);
 - b. _____
12. The following which may be delivered or issued on or after the Effective Date of the Agreement and are not attached hereto:
 - a. Written Amendments;
 - b. Work Orders;
 - c. Change Order(s).

The documents listed in paragraph 8.01.A are attached to this Agreement (except as expressly noted otherwise above).

There are no Contract Documents other than those listed above in this Article 8.

ARTICLE 9 MISCELLANEOUS

9.01 Terms

Terms used in this Agreement will have the meanings indicated in the General Conditions.

9.02 Assignment of Agreement

No assignment by a party hereto of any rights under or interests in the Agreement will be binding on another party hereto without the written consent of the party sought to be bound; and,

specifically but without limitation, moneys that may become due and moneys that are due may not be assigned without such consent (except to the extent that the effect of this restriction may be limited by law), and unless specifically stated to the contrary in any written consent to an assignment, no assignment will release or discharge the assignor from any duty or responsibility under the Contract Documents.

9.03 Successors and Assigns

OWNER and CONTRACTOR each binds itself, its partners, successors, assigns, and legal representatives to the other party hereto, its partners, successors, assigns, and legal representatives in respect to all covenants, agreements, and obligations contained in the Contract Documents.

9.04 Severability

Any provision or part of the Contract Documents held to be void or unenforceable under any Law or Regulation shall be deemed stricken, and all remaining provisions shall continue to be valid and binding upon OWNER and CONTRACTOR, who agree that the Contract Documents shall be reformed to replace such stricken provision or part thereof with a valid and enforceable provision that comes as close as possible to expressing the intention of the stricken provision.

IN WITNESS WHEREOF, OWNER and CONTRACTOR have signed this Agreement in duplicate. One counterpart each has been delivered to OWNER and CONTRACTOR. All portions of the Contract Documents have been signed or identified by OWNER and CONTRACTOR or on their behalf.

This Agreement will be effective on _____, _____
(which is the Effective Date of the Agreement)

OWNER:

CONTRACTOR:

By: _____

By: _____

(CORPORATE SEAL)

(CORPORATE SEAL)

Attest _____

Attest _____

Address for giving notices: _____

Address for giving notices: _____

(If OWNER is a corporation, attach evidence of authority to sign. If OWNER is a public body, attach evidence of authority to sign and resolution or other documents authorizing execution of OWNER – CONTRACTOR Agreement)

License No. _____

(Where applicable)

Agent for service of process: _____

(If CONTRACTOR is a corporation or a partnership, attach evidence of authority to sign.)

Designated Representative:

Designated Representative:

Name: _____

Name: _____

Title: _____

Title: _____

Address: _____

Address: _____

Phone: _____

Phone: _____

FAX: _____

FAX: _____

PERFORMANCE BOND

Any singular reference to CONTRACTOR, Surety, OWNER or other party shall be considered plural where applicable.

CONTRACTOR (Name and Address):	SURETY (Name and Address of Principal Place of Business): _____

OWNER:
Northfield Township
8350 Main St
Whitmore Lake, MI 48189

CONTRACT

Date:
Amount:
Description: Northfield Township Hall Parking Lot
Northfield Township

BOND

Date (Not earlier than Contract Date):
Amount:
Modifications to this Bond Form:

Surety and CONTRACTOR, intending to be legally bound hereby, subject to the terms printed on the reverse side hereof, do each cause this Performance Bond to be duly executed on its behalf by its authorized officer, agent or representative.

CONTRACTOR AS PRINCIPAL	SURETY
Company: _____ (Corp. Seal)	Company: _____ (Corp. Seal)
Signature: _____	Signature: _____
Name & Title: _____	Name & Title: _____ (Attach Power of Attorney)

(Space is provided below for signatures of additional parties, if required).

CONTRACTOR AS PRINCIPAL	SURETY
Company: _____ (Corp. Seal)	Company: _____ (Corp. Seal)
Signature: _____	Signature: _____
Name & Title: _____	Name & Title: _____ (Attach Power of Attorney)

1. The CONTRACTOR and the Surety, jointly and severally, bind themselves, their heirs, executors, administrators, successors and assigns to the OWNER for the performance of the Contract, which is incorporated herein by reference.
2. If the CONTRACTOR performs the Contract, the Surety and the CONTRACTOR have no obligation under this Bond, except to participate in conferences as provided in paragraph 3.1
3. If there is no OWNER Default, the Surety's obligation under this Bond shall arise after:
 - 3.1. The OWNER has notified the CONTRACTOR and the Surety at the addresses described in paragraph 10 below, that the OWNER is considering declaring a CONTRACTOR Default and has requested and attempted to arrange a conference with the CONTRACTOR and the Surety to be held not later than fifteen days after receipt of such notice to discuss methods of performing the Contract. If the OWNER, the CONTRACTOR and the Surety agree, the CONTRACTOR shall be allowed a reasonable time to perform the Contract, but such an agreement shall not waive the OWNER's right, if any, subsequently to declare a CONTRACTOR Default; and
 - 3.2. The OWNER has declared a CONTRACTOR Default and formally terminated the CONTRACTOR's right to complete the Contract. Such CONTRACTOR Default shall not be declared earlier than twenty days after the CONTRACTOR and the Surety have received notice as provided in paragraph 3.1; and
 - 3.3. The OWNER has agreed to pay the Balance of the Contract Price to:
 - 3.3.1. The Surety in accordance with the terms of the Contract;
 - 3.3.2. Another contractor selected pursuant to paragraph 4.3 to perform the Contract.
4. When the OWNER has satisfied the conditions of paragraph 3, the Surety shall promptly and at the Surety's expense take one of the following actions:
 - 4.1. Arrange for the CONTRACTOR, with consent of the OWNER, to perform and complete the Contract; or
 - 4.2. Undertake to perform and complete the Contract itself, through its agents or through independent contractors; or
 - 4.3. Obtain bids or negotiated proposals from qualified contractors acceptable to the OWNER for a contract for performance and completion of the Contract, arrange for a contract to be prepared for execution by the OWNER and the contractor selected with the OWNER's concurrence, to be secured with performance and payment bonds executed by a qualified surety equivalent to the Bonds issued on the Contract, and pay to the OWNER the amount of damages as described in paragraph 6 in excess of the Balance of the Contract Price incurred by the OWNER resulting from the CONTRACTOR Default; or
 - 4.4. Waive its right to perform and complete, arrange for completion, or obtain a new contractor and with reasonable promptness under the circumstances;
 - 4.4.1. After investigation, determine the amount for which it may be liable to the OWNER and, as soon as practicable after the amount is determined, tender payment therefore to the OWNER; or

4.4.2. Deny liability in whole or in part and notify the OWNER citing reasons therefore.

5. If the Surety does not proceed as provided in paragraph 4 with reasonable promptness, the Surety shall be deemed to be in default on the Bond fifteen days after receipt of an additional written notice from the OWNER to the Surety demanding that the Surety perform its obligations under this Bond, and the OWNER shall be entitled to enforce any remedy available to the OWNER. If the Surety proceeds as provided in paragraph 4.4, and the OWNER refuses the payment tendered or the Surety has denied liability, in whole or in part, without further notice the OWNER shall be entitled to enforce any remedy available to the OWNER.
6. After the OWNER has terminated the CONTRACTOR's right to complete the Contract, and if the Surety elects to act under paragraph 4.1, 4.2, or 4.3 above, then the responsibilities of the Surety to the OWNER shall not be greater than those of the CONTRACTOR under the Contract, and the responsibilities of the OWNER to the Surety shall not be greater than those of the OWNER under the Contract. To a limit of the amount of this Bond, but subject to commitment by the OWNER of the Balance of the Contract Price to mitigation of costs and damages on the Contract, the Surety is obligated without duplication for:
 - 6.1. The responsibilities of the CONTRACTOR for correction of defective Work and completion of the Contract;
 - 6.2. Additional legal, design professional and delay costs resulting from the CONTRACTOR's Default, and resulting from the actions or failure to act of the Surety under paragraph 4; and
 - 6.3. Liquidated damages, or if no liquidated damages are specified in
7. The Surety shall not be liable to the OWNER or others for obligations of the CONTRACTOR that are unrelated to the Contract, and the Balance of the Contract Price shall not be reduced or set off on account of any such unrelated obligations. No right of action shall accrue on the bond to any person or entity other than the OWNER or its heirs, executors, administrators, or successors.
8. The Surety hereby waives notice of any change, including changes of time, to the Contract or to related subcontracts, purchase orders and other obligations.
9. Any proceeding, legal or equitable, under this Bond may be instituted in any court of competent jurisdiction in the location in which the Work or part of the Work is located and shall be instituted within two years after CONTRACTOR Default or within two years after the CONTRACTOR ceased working or within two years after the Surety refuses or fails to perform its obligations under this Bond, whichever occurs first. If the provisions of this paragraph are void or prohibited by law, the minimum period of limitation available to sureties as a defense in the jurisdiction of the suit shall be applicable.
10. Notice to the Surety, the OWNER or the CONTRACTOR shall be mailed or delivered to the address shown on the signature page.
11. When this Bond has been furnished to comply with a statutory or other legal requirement in the location where the Contract was being performed, any provision in this Bond conflicting with said statutory or legal requirement shall be deemed deleted here from and provisions conforming to such statutory or other legal requirement shall be deemed incorporated herein. The intent is that this Bond shall be construed as a

statutory bond and not as a common law bond.

12. Definitions.

12.1. Balance of the Contract Price:
The total amount payable by the OWNER to the CONTRACTOR under the Contract after all proper adjustments have been made, including allowance to the CONTRACTOR or any amounts received or to be received by the OWNER in settlement of insurance or other Claims for damages to which the CONTRACTOR is entitled, reduced by all valid and proper payments made to or on behalf of the CONTRACTOR under the Contract.

12.2. Contract: the agreement between the OWNER and the CONTRACTOR identified on the signature page, including all Contract Documents and changes thereto.

12.3. CONTRACTOR Default: Failure of the CONTRACTOR, which has neither been remedied nor waived, to perform or otherwise to comply with the terms of the Contract.

12.4. OWNER Default: Failure of the OWNER, which has neither been remedied nor waived, to pay the CONTRACTOR as required by the contract or to perform and complete or comply with the other terms thereof.

End of Section

PAYMENT BOND

Any singular reference to CONTRACTOR, Surety, OWNER or other party shall be considered plural where applicable.

CONTRACTOR (Name and Address): SURETY (Name and Address of Principal Place of Business):

OWNER: Northfield Township 8350 Main St Whitmore Lake, MI 48189

CONTRACT Date: Amount: Description: Northfield Township Hall Parking Lot Northfield Township

BOND Date (Not earlier than Contract Date): Amount: Modifications to this Bond Form:

Surety and CONTRACTOR, intending to be legally bound hereby, subject to the terms printed on the reverse side hereof, do each cause this Payment bond to be duly executed on its behalf by its authorized officer, agent, or representative.

CONTRACTOR AS PRINCIPAL SURETY Company: (Corp. Seal) Signature: Name and Title: (Attach Power of Attorney)

(Space is provided below for signatures of additional parties, if required).

CONTRACTOR AS PRINCIPAL SURETY Company: (Corp. Seal) Signature: Name & Title: (Attach Power of Attorney)

1. The CONTRACTOR and the Surety, jointly and severally, bind themselves, their heirs, executors, administrators, successors and assigns to the OWNER to pay for labor, materials and equipment furnished for use in the performance of the Contract, which is incorporated herein by reference.
2. With respect to the OWNER, this obligation shall be null and void if the CONTRACTOR:
 - 2.1. Promptly makes payment, directly or indirectly, for all sums due Claimants, and
 - 2.2. Defends, indemnifies and holds harmless the OWNER from all claims, demands, liens or suits by any person or entity who furnished labor, materials or equipment for use in the performance of the Contract, provided the OWNER has promptly notified the CONTRACTOR and the Surety (at the addresses described in paragraph 12) of any claims, demands, liens or suits and tendered defense of such claims, demands, liens or suits to the CONTRACTOR and the Surety, and provided there is no OWNER Default.
3. With respect to Claimants, this obligation shall be null and void if the CONTRACTOR promptly makes payment, directly or indirectly, for all sums due.
4. The Surety shall have no obligation to Claimants under this Bond until:
 - 4.1. Claimants who are employed by or have a direct contract with the CONTRACTOR have given notice to the surety (at the addresses described in paragraph 12) and sent a copy, or notice thereof, to the OWNER, stating that a claim is being made under this Bond and, with substantial accuracy, the amount of the claim.
 - 4.2. Claimants who do not have a direct contract with the CONTRACTOR:
 - 4.2.1. Have furnished written notice to the CONTRACTOR and sent a copy, or notice thereof, to the OWNER, within 90 days after having last performed labor or last furnished materials or equipment included in the claim stating, with substantial accuracy, the amount of the claim and the name of the party to whom the materials were furnished or supplied or for whom the labor was done or performed; and
 - 4.2.2. Have either received a rejection in whole or in part from the CONTRACTOR, or not received within 30 days of furnishing the above notice any communication from the CONTRACTOR by which the CONTRACTOR had indicated the claim will be paid directly or indirectly; and
 - 4.2.3. Not having been paid within the above 30 days, have sent a written notice to the Surety and sent a copy, or notice thereof, to the OWNER, stating that a claim is being made under this Bond and enclosing a copy of the previous written notice furnished to the CONTRACTOR.
5. If a notice required by paragraph 4 is given by the OWNER to the CONTRACTOR or to the Surety, that is sufficient compliance.
6. When the Claimant has satisfied the conditions of paragraph 4, the Surety shall promptly and at the Surety's expense take the following actions:
 - 6.1. Send an answer to the Claimant, with a copy to the OWNER, within 45 days after receipt of the claim, stating the amounts that are undisputed and the basis for challenging any amounts that are disputed.
 - 6.2. Pay or arrange for payment of any undisputed amounts.
7. The Surety's total obligation shall not exceed the amount of this Bond, and the amount of this Bond shall be credited for any payments made in good faith by the Surety.
8. Amounts owed by the OWNER to the CONTRACTOR under the Contract shall be used for the performance of the Contract and to satisfy claims, if any, under any Performance Bond. By the CONTRACTOR

furnishing and the OWNER accepting this Bond, they agree that all funds earned by the CONTRACTOR in the performance of the Contract are dedicated to satisfy obligations of the CONTRACTOR and the Surety under this Bond, subject to the OWNER's priority to use the funds for the completion of the Work.

9. The Surety shall not be liable to the OWNER, Claimants or others for obligations of the CONTRACTOR that are unrelated to the Contract. The OWNER shall not be liable for payment of any costs or expenses of any Claimant under this Bond, and shall have under this Bond no obligations to make payments to, give notices on behalf of, or otherwise have obligations to Claimants under this Bond.
10. The Surety hereby waives notice of any change, including changes of time, to the Contract or to related subcontracts, purchase orders and other obligations.
11. No suit or action shall be commenced by a Claimant under this Bond other than in a court of competent jurisdiction in the location in which the Work or part of the Work is located or after the expiration of one year from the date (1) on which the Claimant gave the notice required by paragraph 4.1 or paragraph 4.2.3, or (2) on which the last labor or service was performed by anyone or the last materials or equipment were furnished by anyone under the Construction Contract, whichever of (1) or (2) first occurs. If the provisions of this paragraph are void or prohibited by law, the minimum period of limitation available to sureties as a defense in the jurisdiction of the suit shall be applicable.
12. Notice to the Surety, the OWNER or the CONTRACTOR shall be mailed or delivered to the addressee shown on the signature page. Actual receipt of notice by Surety, the OWNER or the CONTRACTOR, however accomplished, shall be sufficient compliance as of the date received at the address shown on the signature page.
13. When this Bond has been furnished to comply with a statutory or other legal requirement in

the location where the Contract was to be performed, any provision in the Bond conflicting with said statutory or legal requirement shall be deemed deleted herefrom and provisions conforming to such statutory or other legal requirement shall be deemed incorporated herein. The intent is, that this Bond shall be construed as a statutory Bond and not as a common law bond.

14. Upon request of any person or entity appearing to be a potential beneficiary of this Bond, the CONTRACTOR shall promptly furnish a copy of the Bond or shall permit a copy to be made.

15. DEFINITIONS

15.1. Claimant: an individual or entity having a direct contract with the CONTRACTOR or with a Subcontractor of the CONTRACTOR to furnish labor, material or equipment for use in the performance of the Contract. The intent of this Bond shall be to include without limitation in the terms "labor, materials or equipment" that part of water, gas, power, light, heat, oil, gasoline, telephone service or rental equipment used in the Contract, architectural and engineering services required for performance of the Work of the CONTRACTOR and the CONTRACTOR's Subcontractors, and all other items for which a mechanic's lien may be asserted in the jurisdiction where the labor, materials or equipment were furnished.

15.2. Contract: The agreement between the OWNER and the CONTRACTOR identified on the signature page, including all Contract Documents and changes thereto.

15.3. OWNER Default: Failure of the OWNER, which has neither been remedied nor waived, to pay the CONTRACTOR as required by the Contract or to perform and complete or comply with the other terms thereof.

End of Section

MAINTENANCE AND GUARANTEE BOND

KNOW ALL MEN BY THESE PRESENTS, That we _____ (contractor name), as Principal, and _____, as Surety, are held and firmly bound unto the Northfield Township, 8350 Main St, Whitmore Lake, MI 48189, as Owner, in the sum of _____ DOLLARS and _____ CENTS (\$ _____) good and lawful money of the United States of America, to be paid to said Northfield Township, its legal representatives and assigns for which payment well and truly to be made, we bind ourselves, our heirs, executors, administrators, successors and assigns, and each and every one of them jointly and severally, firmly by these presents.

Sealed with our seals and dated this _____ day of _____ A.D. 20 _____.

WHEREAS, the above named Principal has entered into a certain written Contract with Northfield Township dated this _____ day of _____ A.D. 20 _____, wherein the said Principal covenanted and agreed to follows, to-wit: TO CONSTRUCT THE WORK IN ACCORDANCE WITH THE SPECIFICATIONS, CONTRACT DOCUMENTS AND DRAWINGS TITLED: Northfield Township Hall Parking Lot, OHM JOB NO. 0151-23-0030.

NOW, THEREFORE, THE CONDITION OF THIS OBLIGATION IS SUCH, that by and under said Contract, the above named Principal has agreed with the Northfield Township that for a period of TWO year(s) from date of payment of Final Estimate, to keep in good order and repair any defect in all work done under said Contract either by the Principal or his Subcontractors, or his material suppliers, that may develop during said period due to improper materials, defective equipment, workmanship or arrangements, and any other work affected in making good such imperfections, shall also be made good all without expense to the OWNER, excepting only such parts or part of said work as may have been disturbed without consent or approval of the Principal after final acceptance of the work, and that whenever directed to do so by the OWNER by notice served in writing, either personally or by mail, on the Principal at _____ (contractor's city, state, and zip code),

_____ legal representatives, or successors, or on the Surety at _____ WILL PROCEED at once to make such repairs as directed by said OWNER; and in case of failure so to do within one week from the date of service of such notice, or within reasonable time not less than one week, as shall be fixed in said notice, then the said OWNER shall have the right to purchase such materials and employ such labor and equipment as may be necessary for the purpose, and to undertake, do and make such repairs and charge the expense thereof to, and receive same from, said Principal or Surety. If any repair is necessary to be made at once to protect life and property, then and in that case, the said OWNER may take immediate steps to repair or barricade such defects without notice to the CONTRACTOR. In such accounting the said OWNER shall not be held to obtain the lowest figures for the doing of the work, or any part thereof, but all sums actually paid therefore shall be charged to the Principal or Surety. In this connection the judgment of the OWNER is final and conclusive. If the said Principal for a period of TWO year(s) from the date of payment of Final Estimate, shall keep said work so constructed under said Contract in good order and repair, excepting only such part or parts of said work which may have been disturbed without the consent or approval of said Principal after final acceptance of same, and shall whenever notice is given as hereinbefore specified, at once proceed to make repair as in said notice directed, or shall reimburse said OWNER for any expense incurred by making such repairs, should the Principal or Surety fail to do as hereinbefore specified, and shall fully indemnify, defend and save harmless the said Owner and Orchard, Hiltz & McCliment, Inc. from all suits and actions for damages of every name and description brought or claimed against it for, or on account of, any injury or damage to person or property received or sustained by any party or parties, by or from any of the acts or omissions or through the negligence of said

Principal, servants, agents or employees, in the prosecution of the work included in said Contract, and from any and all claims arising under the Workman's Compensation Act, so-called, of the State of Michigan, then the above obligation shall be void, otherwise to remain in full force and effect.

IN WITNESS WHEREOF, the parties hereto have caused this instrument to be executed by their respective authorized officers this _____ day of _____ A.D., 20 _____.

Signed, Sealed and Delivered
In the Presence of:

Signature

Signature

Name

Name

Principal

Signature

Signature

Name

Name

Surety

CONTRACTOR'S AFFIDAVIT

STATE OF MICHIGAN)
)SS.
COUNTY OF _____)

The undersigned, _____, CONTRACTOR, hereby represents that on _____, 20____ he (it) was awarded a Contract by Northfield Township hereinafter called the OWNER, to construct Northfield Township Hall Parking Lot in accordance with the terms and conditions of Contract No. _____; and the undersigned further represents that the subject work has now been accomplished and the said Contract has now been completed.

The undersigned hereby warrants and certifies that all of his (its) indebtedness arising by reason of said Contract has been fully or satisfactorily secured, and that all claims from subcontractors and others for labor and material used in accomplishing the said project, as well as all other claims arising from performance of said Contract, have been fully paid or satisfactorily secured. The undersigned further agrees that if any such claim should hereafter arise, he (it) shall assume responsibility for same immediately upon request to do so by the OWNER.

The undersigned, for a valuable consideration, receipt of which is hereby acknowledged, does further hereby waive, release and relinquish any and all claims or right of lien which the undersigned now has or may hereafter acquire upon the subject premises for labor and material used in accomplishing said project owned by the OWNER.

This affidavit is freely and voluntarily given with full knowledge of the facts on this ____ day of _____, 20_____.

Contractor

By: _____

Title _____

Subscribed and sworn to before me, a Notary Public in and for _____ County, Michigan, on this _____ day of _____, 20_____.

Notary Public: _____

My Commission expires: _____

CONTRACTOR'S DECLARATION

I HEREBY DECLARE THAT I HAVE NOT, during the period

_____ to

_____ A.D., 20 _____ performed any work, furnished any material, sustained any loss, damage or delay for any reason, including soil conditions encountered or created, or otherwise done anything for which I shall ask, demand, sue for or claim compensation from Northfield Township or his agents, in addition to the regular items set forth in the Contract numbered _____ and dated _____ A.D., 20 _____ for the Agreement executed between myself and the OWNER, and in the Change Orders for work issued by the OWNER in writing as provided thereunder, except as I hereby make claim for additional compensation and/or extension of time, as set forth on the itemized statement attached hereto.

There (is) (is not) an itemized statement attached.

Date: _____

By: _____

Title: _____

SWORN STATEMENT

State of Michigan

County of: : _____ Date: _____

_____ (deponent) being duly sworn deposes and says:

1. That _____ is the Contractor/Subcontractor for an improvement to the property described on the following page.
2. That the following is a statement of each subcontractor and supplier and laborer, for which the payment of wages or fringe benefits and withholdings is due but unpaid, with whom the Contractor/Subcontractor has Contracted/Subcontracted for performance under the Contract with the Owner or Lessee of the property, and that the amounts due to the persons as of the date hereof are correctly and fully set forth opposite their names as follows:

Name of Subcontractor, Supplier or Laborer	Type of Improvement Furnished	Total Contract Price	Amount Already Paid	Amount Currently Owing	Amount of Laborer Wages Due but Unpaid	Amount of Labor, Fringe Benefits & Withholdings due but Unpaid

The contracts or subcontracts cited herein are for improvement to the following described real property situated in Washtenaw County, Michigan, described as:

(Insert legal description of property) _____

Commonly known as:

Northfield Township Hall Parking Lot

OHM Job Number:

0151-23-0030

- 3. That the Contractor has not procured material from, or subcontracted with, any person other than those set forth above and owes no money for the improvement other than the sums set forth above.
- 4. Deponent further says that he makes the foregoing statement as the Contractor/Subcontractor or as Controller of the Contractor/Subcontractor for the purpose of representing to the owner of the above described premises and his agents that the above described property is free from claims of construction liens, or the possibility of construction liens, except as specifically set forth above and except for claims of construction liens by laborers which may be provided pursuant to Section 109 of the Construction Lien Act, Act No. 497 of the Public Acts of 1980, as amended, being Section 570.1109 of the Michigan Compiled Laws.

WARNING TO OWNER: An Owner of the above described property may not rely on this sworn statement to avoid the claim of a Subcontractor, Supplier or Laborer who has provided a Notice of Furnishing (or a Laborer who may provide a Notice of Furnishing pursuant to Section 109 of the Construction Lien Act) to the Designee or to the Owner if the Designee is not named or has died.

Dated: _____

Signature of Deponent

WARNING TO DEPONENT: A person, who with intent to defraud, gives a false sworn statement is subject to criminal penalties as provided in Section 110 of the Construction Lien Act, Act No. 497 of the Public Acts of 1980, as amended, being Section 570.1110 of the Michigan Compiled Laws.

Subscribed and sworn to before me on: _____ in _____ County, Michigan

My commission expires: _____ Signature: _____

GENERAL CONDITIONS

Table of Contents

General	3
1. Definitions	3
2. Contract Documents	3
3. Bonds	4
4. Contract Drawings & Specifications	4
5. Coordination of Contract Documents	4
6. Preconstruction Meeting	5
7. Reuse of Documents	5
8. Availability of Lands	5
9. Physical Conditions	6
10. General Requirements of Materials & Workmanship	6
11. Shop Drawings & Special Drawings	6
12. Changes in Quantities or Plans	7
13. Estimated Quantities	7
14. Payments	7
15. Extension of Time	8
16. Authority	9
17. Progress of Work	9
18. Time is Essence of Contract	9
19. Commencement of Contract Time	9
Owner Responsibilities	9
20. Extra & Force Account Work	9
21. Payments Withheld	12
22. Use of Complete Portions of the Work	12
Engineer Responsibilities	12
23. Engineer During Construction	12
24. Authority & Duties of Construction Observer	12
25. Limitations on Engineer's Responsibilities	13
26. Lines & Grades	13
27. Testing & Sampling	13
Contractor Responsibilities	15
28. Unforeseen Physical Conditions	15
29. Composition of the Contractor	15
30. Assignment of Contract	15
31. Agents	15
32. Safety & Protection	15
33. Contractor's Supervision & Origination	16
34. Contractor's Right to Stop Work	17
35. Storage of Materials	17
36. Cleaning Up	17
37. Sunday & Night Work	17
38. Sanitary Regulations	17
39. Permits & Regulations	17
40. Guarantee	18
41. Patents	18

42.	Information by the Contractor.....	18
43.	Forfeiture of Contract.....	18
44.	Relation to Other Contractors.....	19
45.	“Or Equal” Clause	19
	Legal	19
46.	Indemnification.....	19
47.	Controlling Law.....	20
48.	No Waiver of Contract.....	20
49.	Dispute Resolution.....	20
50.	Giving Notice.....	20
51.	Cumulative Remedies.....	20

General

1. DEFINITIONS

The following terms as used in the Contract Documents are respectively defined as follows:

“Agreement”: The written document between the OWNER and the CONTRACTOR concerning the work to be performed.

“Change Order” - A document recommended by ENGINEER, which is signed by CONTRACTOR and OWNER and authorizes an addition, deletion or revision in the Work, or an adjustment in the Contract Price or the Contract Time, issued on or after the Effective Date of the Agreement.

“Contract” – The entire and integrated written agreement between the OWNER and CONTRACTOR concerning the Work. The Contract supersedes prior negotiations, representations, or agreements, whether written or oral.

“CONTRACTOR”: The person, firm or corporation to whom the Contract is awarded by the OWNER and who is subject to the terms thereof and party of the second part of the Agreement.

“ENGINEER”: Orchard, Hiltz & McCliment, Inc., Livonia, Michigan

“Construction Observer”: The authorized representative of ENGINEER who is assigned to the site or any part thereof.

“OWNER”: The public body or authority, corporation, association, firm or person with whom CONTRACTOR has entered into the Agreement: and for whom the work is to be provided; and the party of the first part of the Contract.

“Project Manual” – The bound documentary information prepared for bidding and constructing the Work. A listing of the contents of the Project Manual, which may be bound in one or more volumes, is contained in the table(s) of contents.

“Specifications” - Those portions of the Contract Documents consisting of written technical descriptions of materials, equipment, construction systems, standards and workmanship as applied to the Work and certain administrative details applicable thereto.

“Subcontractor”: A person, firm or corporation having a direct contract with CONTRACTOR or with any other subcontractor for the performance of a part of the Work at the site.

“Supplier”: A manufacturer, fabricator, supplier, distributor, material man or vendor.

“Supplemental Conditions”: The part of the Contract Documents that amends or supplements the General Conditions and/or the Insurance Specifications and the Bond Requirements.

“Work” - The entire completed construction or the various separately identifiable parts thereof required to be furnished under the Contract Documents. Work is the result of performing services, furnishing labor and furnishing and incorporating materials and equipment into the construction, all as required by the Contract Documents.

“Written Notice”: Shall be deemed to have been “duly served” when such notice shall have been given or mailed to the CONTRACTOR or his superintendent at the site of the Work or when such notice shall have been given or mailed to the OWNER.

2. CONTRACT DOCUMENTS

The original and three counterparts of the Contract shall be signed by the OWNER and the CONTRACTOR.

The Work under this Contract shall consist of the items listed in the Bid Form, including all incidentals necessary to fully complete the project in accordance with the Contract Documents. The Contract Documents shall consist of the Advertisement, Instructions to Bidders, Supplemental Instructions to Bidders, Supplemental Specifications, Bid Form, Project Plans and Drawings, Standard Plans and Details, Technical Specifications,

General Conditions, General Specifications, Method of Payment, Insurance, Bonds and Agreement.

The Contract Documents comprise the entire agreement between OWNER and CONTRACTOR. The Contract Documents are complimentary, and what is called for by any one shall be as binding as if called for by all. The intent of the Contract Documents is to include in the Contract Price the cost of all labor and material, water, fuel, tools, plant, equipment, light, transportation and all other expenses that may be necessary for the proper execution and completion of the Work.

3. BONDS

The CONTRACTOR shall furnish a surety bond (form included) in an amount at least equal to 100 percent of the Contract Price as security for faithful performance of this Contract. CONTRACTOR shall also furnish a separate surety bond (form included) in an amount at least equal to 100 percent of the Contract Price as security for the payment of all persons performing labor on the project under this Contract, and furnishing materials in connection with this Contract. The Surety on each such bond shall be a duly authorized surety company satisfactory to the OWNER.

The CONTRACTOR shall furnish a Maintenance and Guarantee Bond (form included) covering all Work under this Contract. The guarantee is to cover fifty percent (50%) of the contract amount for a period of two (2) years subsequent to the date of final payment unless otherwise specified.

Should any Surety upon any bond furnished in connection with this Contract become unacceptable to the OWNER, or if any such Surety shall fail to furnish reports as to his financial condition from time to time as requested by the ENGINEER, the CONTRACTOR must promptly furnish such additional security as may be required from time to time by the ENGINEER to protect the interests of the OWNER or persons supplying labor or materials in the

prosecution of the Work contemplated by the Contract.

4. CONTRACT DRAWINGS & SPECIFICATIONS

The original drawings prepared by the ENGINEER and included in the Contract Documents may be supplemented by other drawings furnished by the CONTRACTOR and approved by the ENGINEER or supplied to the CONTRACTOR by the ENGINEER during progress of the Work as he may deem to be necessary or expedient. All such supplementary Contract Drawings or instructions are intended to be consistent with the Contract Documents, true developments thereof, and reasonably inferable therefrom. Therefore, no extra charge will be allowed on a claim that particular supplemental contract drawings or instructions differed from the Contract Documents, incurring extra work, unless CONTRACTOR has first brought the matter, in writing, to the ENGINEER's attention for proper adjustment before starting on the work covered by such, and has received from the ENGINEER an order, in writing, to so proceed.

These original and supplemental drawings constitute the drawings according to which the Work is to be done. The CONTRACTOR shall keep at the site of the Work an approved or confirmed copy of all drawings and specifications, and shall at all times give the ENGINEER and OWNER access thereto.

5. COORDINATION OF CONTRACT DOCUMENTS

In case of discrepancy, figured dimensions shall govern over scaled dimensions and the parts of the Contract will prevail over all other parts of the following order:

Supplemental Specifications

Supplemental Instructions to Bidders

Instructions to Bidders

Bid Form

Project Plans and Drawings

Standard Plans & Details

Method of Payment

Technical Specifications

General Conditions

General Specifications

Insurance Specifications and Bond Forms

The CONTRACTOR shall not take advantage of any apparent error or omission in the Contract Documents, and if any inconsistency, omission, or conflict is discovered in the Contract Documents, or if in any place the meaning of the Contract Documents is obscure, uncertain, or in dispute, the ENGINEER will decide as to the true intent.

Information regarding site of the Work given in drawings and specifications has been obtained by the ENGINEER and is believed to be reasonably correct, but the OWNER does not warrant either the completeness or accuracy of such information, and it is the CONTRACTOR's responsibility to verify all such information.

6. PRECONSTRUCTION MEETING

A preconstruction meeting will be held prior to the beginning of any work. The ENGINEER will schedule the meeting as soon as possible after acceptable executed Contract Documents are received from the CONTRACTOR.

Notice of the meeting will be made to the OWNER, the CONTRACTOR, and to the following applicable entities, contingent upon their interest in the project:

Utility Companies

County Road Commission

Michigan Department of Transportation (MDOT)

Michigan Department of Labor-Safety Division

Railroad Companies

Other State, Local and County Agencies

The purpose of the preconstruction meeting is to discuss particular procedures and potential problem areas. The CONTRACTOR is given updates on the conditions of the proposed construction and what is expected as to proper notification in the event of damage to existing utilities.

The CONTRACTOR shall submit in writing at the preconstruction meeting the following information:

Schedule of construction

Sources of materials

Final list of subcontractors

The designated safety officer on the job

Superintendent for the project

Foreman in charge on the job site

Emergency and after hours phone numbers for CONTRACTOR, including Safety Officer, Superintendent and Foreman.

Approval by ENGINEER and OWNER of any construction schedule indicating completion of the work in less time than allotted by the Contract shall not be construed as an acknowledgment, either express or implied, that the work can be completed within the time shown on this schedule, and shall not under any circumstances give rise to a cause of action for damages by the CONTRACTOR.

7. REUSE OF DOCUMENTS

Neither CONTRACTOR nor any subcontractor or supplier or other person or organization performing or furnishing any of the Work under a direct or indirect contract with OWNER shall have or acquire any title to or ownership rights in any of the drawings, specifications or other documents (or copies of any thereof) prepared by or bearing the seal of ENGINEER; and they shall not reuse any of them on extensions of the project or any other project without written consent of OWNER and ENGINEER and specific written verification or adaptation by ENGINEER.

8. AVAILABILITY OF LANDS

OWNER shall furnish, as indicated in the Contract Documents, the lands upon which the work is to be performed, rights-of-way for access thereto, and such other lands which are designated for the use of CONTRACTOR. CONTRACTOR shall provide for all additional lands and access thereto that may be required for temporary construction facilities or storage of materials and equipment.

Permission to use private property shall be obtained prior to any such use by the CONTRACTOR. Written evidence of such permission shall be given to the ENGINEER prior to any such use.

9. PHYSICAL CONDITIONS

Reference is made to the Supplemental Instructions to Bidders for identification of those reports of investigations and tests of subsurface and latent physical conditions at the site or otherwise affecting cost, progress or performance of the Work which have been relied upon by the ENGINEER in preparation of the drawings and specifications. Such reports are not guaranteed as to accuracy or completeness and are not part of the Contract Documents.

10. GENERAL REQUIREMENTS OF MATERIALS & WORKMANSHIP

In the specifications where a particular material or piece of equipment is specified by reference to some particular make or type, or equal, it is not the intent to limit competition but to set up by such reference a standard of quality most easily understood and defined. If materials or equipment of other make or type other than that specified by name are offered by CONTRACTOR they will be given full consideration by the ENGINEER, and the ENGINEER's decision will be final as to whether the materials or equipment offered are equal to those specified.

Unless otherwise stipulated in the specifications, all equipment, materials and articles incorporated in the Work covered by this Contract are to be new and of the best grade of their respective kinds for the

purpose. The CONTRACTOR shall, if required, furnish such evidence as to kind and quality of materials as the ENGINEER may require.

The CONTRACTOR shall furnish suitable tools and building appliances and employ competent labor to perform the work to be done, and any labor, tools or appliances that shall not, in the judgment of the ENGINEER, be suitable or competent to produce this result may be ordered from the Work by him, and such labor, tools or appliances shall be substituted therefore by the CONTRACTOR as will meet with the approval of the ENGINEER.

If not otherwise provided, material or work called for in this Contract shall be furnished and performed in accordance with well-known established practice and standards recognized by architects, engineers and the trade.

11. SHOP DRAWINGS & SPECIAL DRAWINGS

Where called for in the specifications, CONTRACTOR shall submit to the ENGINEER for approval in not less than five copies, details, specifications, cuts and drawings of such equipment and structural work as may be required. CONTRACTOR shall make any changes or alterations required by the ENGINEER and resubmit same without delay. Approval of the ENGINEER shall not relieve the CONTRACTOR of responsibility for errors in the drawings, as the ENGINEER's checking is intended to cover compliance with the drawings and specifications and not to enter into every detail of the shop work. No work shall be undertaken until the ENGINEER has approved the shop drawings.

When the work of the CONTRACTOR is of a nature originating with it, full general and detail drawings shall be furnished to the ENGINEER on 24" x 36" size sheets of polyester film base which shall, upon approval, become the property of the OWNER.

It is understood that approval by the ENGINEER of CONTRACTOR's drawings, whether general or detailed, is a general approval relating only to their sufficiency and compliance with waiver of errors, discrepancies or omissions.

12. CHANGES IN QUANTITIES OR PLANS

The OWNER reserves the right to make, by written order, at any time during the Work, such changes in quantities and such alterations in the work as are necessary to satisfactorily complete the project. Such changes in quantities and alterations shall not invalidate the Contract nor release the Surety, and by signing a work order or authorization, the CONTRACTOR agrees to perform the Work as altered and agrees to accept, as payment in full for such Work, the monetary amounts set forth in such written order as balanced by OWNER. In addition, by signing a written order, the CONTRACTOR releases the OWNER from any and all claims for compensation with regard to the items of work specified in the written order; including, but not limited to, any and all claims for delay and overhead, unless the OWNER is notified in writing at the time of signing the authorization that the CONTRACTOR refuses to release the OWNER from such claims. All increases in quantities of work which appear in the Contract as pay items shall be paid for at the Contract Unit Prices. Decreases in quantities included in the Contract shall be deducted from the Contract at the Contract Unit Prices.

13. ESTIMATED QUANTITIES

The quantities of various classes of work to be done and materials to be furnished under this Contract, which have been estimated as stated elsewhere herein, are approximate and only for the purpose of comparing, on a uniform basis, the bids offered for work under this Contract; and neither the OWNER nor the ENGINEER is to be held responsible should any of the said estimated quantities be found incorrect during the construction of the work; and the

CONTRACTOR shall make no claim for anticipated profit, nor for loss of profit, because of a difference between the quantities of the various classes of work actually done or materials actually delivered, and the estimated quantities as herein stated.

14. PAYMENTS

Payments for work completed, as recommended by the ENGINEER, will be made as specified herein.

Partial Payments

CONTRACTOR shall submit to OWNER an application for each payment and shall submit a Contractor's Declaration declaring that he has not performed any work, furnished any material, sustained any loss, damage or delay for any reasons, including soil conditions encountered or created, or otherwise done anything for which he will ask, demand, sue for, or claim compensation from the OWNER other than as indicated on the Contractor's Declaration and shall, if required, submit receipts or other vouchers showing his payments for materials and labor, including payments to subcontractors.

Payments, based on progress estimates, will be made on a monthly basis on work completed during the preceding month, less retainage held in accordance with Public Act No. 524 of 1980.

The retainage shall be as follows:

Not more than ten percent (10%) of the dollar value of all work in place until work is fifty percent (50%) in place.

After the work is fifty percent (50%) in place, additional retainage shall not be withheld unless the OWNER determines that the CONTRACTOR is not making satisfactory progress, or for other specific cause relating to the CONTRACTOR's performance under the Contract. If the OWNER so determines, then the retainage amount shall not be more than ten percent (10%) of the dollar value of work more than fifty percent (50%) in place.

Retainage shall be released to CONTRACTOR together with the final progress payment.

The OWNER may withhold payment of any estimate or portion of estimate until the CONTRACTOR shall have furnished satisfactory evidence that he has paid all claims of every nature. The CONTRACTOR shall submit to the OWNER with each application for payment a "Sworn Statement" attesting to all payments made and balances due to all subcontractors and to all suppliers of materials, fuel, and equipment for the project work completed. He shall also attest to all payments made for labor furnished for the work completed. The "Sworn Statement" shall be in a form acceptable to the OWNER and all suppliers and subcontractors shall be listed along with payments made and balances owed to each.

No partial payment shall be considered as acceptance of the work or any portion thereof prior to final completion of the work, and payment of final estimate.

Final Payment

The CONTRACTOR's request for final payment shall be accompanied by the following documents:

Contractor's Declaration

Contractor's Affidavit

Unconditional waivers, as required, from major suppliers and subcontractors

Release of Surety

Release from other public agencies for which permits have been obtained under this Agreement.

Within thirty (30) days after completion of the work under this Agreement to the satisfaction of the OWNER and ENGINEER, in accordance with all and singular terms and stipulations herein contained, the OWNER shall make final payment, from a final estimate made by the ENGINEER. Before final payment is made, the CONTRACTOR shall, as directed by the OWNER, make a Contractor's Affidavit that he has paid all claims of every nature, or

secured a release from the Surety or Sureties approving payment of the final estimate by the OWNER. Final payment, when made, shall be considered as final approval and acceptance of the completed work herein specified.

The acceptance by the CONTRACTOR of final payment aforesaid shall operate as, and shall be, a release to the OWNER and his agents, from all claim and liability to the CONTRACTOR for anything done or furnished for, relating to, or affecting the work.

Incorrect/Improper Payments

OWNER shall not, nor shall any officer thereof, be precluded or stopped by any return or certificate made or given by the ENGINEER, or other officer, agent or appointee, under the provision of this Agreement, at any time (either before or after final completion and acceptance of the work and payment made therefore pursuant to any such return or certificates showing the true and correct amount of money due therefore, notwithstanding any such return or certificate, or any payment made in accordance therewith) from demanding and receiving from the CONTRACTOR or his sureties, separately or collectively, such sums as may have been improperly paid said CONTRACTOR by reason of any such return or certificate which has been untruly or incorrectly compiled.

15. EXTENSION OF TIME

All days in which work is suspended by order of the ENGINEER, or in accordance with these specifications, shall automatically extend the time for completion an equal number of days.

In the event work is suspended because the CONTRACTOR does not perform, no extension will be allowed for this period of time.

All requests from CONTRACTOR for extensions of time shall be submitted in writing. Such requests shall detail the reason for the request, provide a realistic revised completion date, and indicate any other

areas which may be impacted by such an extension. Such requests must be submitted to the field ENGINEER within ten (10) days after the occurrence of the incident or situation that brought about a reason for extending the time of completion. The final decision of whether or not to grant an extension of time will be made by the field ENGINEER. In no case will a request be considered if it is submitted after the ten (10) day period has passed.

16. AUTHORITY

No officer, agent or employee of the OWNER shall have power to revoke, alter, enlarge, or relax the stipulations or requirements of the Contract Documents, except insofar as such authority may be specifically conferred by the Contract Documents themselves, without formal authorization to do so, conferred by the Agreement, or by ordinance, resolution or other usual official action by the OWNER.

17. PROGRESS OF WORK

The work shall be prosecuted regularly and uninterruptedly, unless the OWNER shall otherwise specifically direct, with such force and at such points as to insure its full completion within the time stated herein.

If, in the opinion of the ENGINEER, it is necessary or advisable that certain portions of the work be done immediately, the CONTRACTOR, upon written order shall proceed with such work without delay. Should he fail to so proceed, the OWNER may do or cause to be done, such work, and the cost of same will be deducted from any money due or to become due the CONTRACTOR under this Agreement.

18. TIME IS ESSENCE OF CONTRACT

It is distinctly understood and agreed to by the parties hereto that the time specified for completion of the Work is the essence of this Agreement, and CONTRACTOR shall not be entitled to claim performance of this Agreement unless the work is satisfactorily completed, in every respect, within the time herein specified.

19. COMMENCEMENT OF CONTRACT TIME

The Contract Times will commence to run on the thirtieth day after the Effective Date of the Agreement or, if a Notice to Proceed is given, on the day indicated in the Notice to Proceed. A Notice to Proceed may be given at any time within thirty (30) days after the Effective Date of the Agreement. In no event will the Contract Times commence to run later than the sixtieth (60) day after the day of Bid Opening or the thirtieth (30) day after the Effective Date of the Agreement, whichever date is earlier.

Owner Responsibilities

20. EXTRA & FORCE ACCOUNT WORK

When extra work is required, it shall be performed and payment for such work will be on the unit price or lump sum basis agreed to in a written order. When such agreement cannot be reached, the OWNER may order such work, including any required offsite work, to be done by force account. The compensation as herein provided shall be accepted by the CONTRACTOR as payment in full for extra work done by force account, and the said percentages shall cover profit, superintendence, general expense, overhead, miscellaneous unforeseen costs, and the use of small tools and equipment. For approved subcontract work, the CONTRACTOR will be paid an amount equal to six percent (6%) of the total cost of the subcontract work, as reimbursement for administrative costs incurred in connection with the subcontract work.

When it is necessary for the CONTRACTOR to hire a firm to perform a specialized type of work or service for which the CONTRACTOR or subcontractors are not qualified to do, payment will be made at the invoice cost. The CONTRACTOR will be paid an amount equal to six percent (6%) of the invoice cost, as reimbursement for administrative costs. Prior approval by the OWNER is required.

REPORTS:

The CONTRACTOR shall furnish to the OWNER, itemized reports of the costs of all force account work. The reports shall be furnished each week and shall include a certified copy of the weekly payroll and copies of bills for the materials used and the freight charges paid on same. Discount for prompt payment or penalty for late payment will not be considered in determining the net amount of the bill. The net amount of the bill shall be charged to the force account work. Where materials used are not specifically purchased for use on extra work but are taken from the CONTRACTOR's stock, the CONTRACTOR shall submit a certification of the quantity, price, and freight on such materials in lieu of original bills and invoices.

The CONTRACTOR shall prepare itemized statements containing the following detailed information:

Labor: Name, classification, dates, number of hours worked each day, total hours computed to nearest half hour, total hours, rate, and extension for each employee engaged.

Equipment: Designation, number of hours used each day (computed to nearest half hour), total hours, rental rate, and extension for each unit of equipment engaged.

Materials: Quantities of materials, with prices per unit and extensions and freight costs when applicable.

The CONTRACTOR and the OWNER shall compare records of force account work and bring them into agreement at the end of each day.

LABOR:

For all labor and for all craft foreman directly engaged in the specific work, the CONTRACTOR will be paid the actual rate of wages and the number of hours paid said labor and foremen in accordance with approved labor agreements, computed to nearest half hour, to which sum twenty-six (26) percent will be added (this sum includes a one (1) percent allowance for the

Single Business Tax). Project foremen will be classified as Superintendents and their compensation will not be included in the payment provided herein.

Bond Premium: Workmen's Compensation Insurance; Personal Injury Public Liability and Property Damage Public Liability Insurance; Unemployment Compensation; Federal Social Security; and payments required to be made to Employer and Employee Trusteships, the proceeds from which accrue exclusively to the benefit of the employee; will be paid for at actual cost, to which sum twenty (20) percent will be added except that twenty-six (26) percent will be added to the taxable fringe benefits. The CONTRACTOR shall furnish satisfactory evidence of the amounts paid for each of these required costs as related to force account work.

MATERIALS:

For materials, the CONTRACTOR will receive the actual cost delivered to the project site, including freight charges, as shown by copies of bills, to which sum fifteen (15) percent will be added.

If a charge in the amount or type of force account work results in a surplus of the material ordered and delivered to the project site, the OWNER will reimburse the CONTRACTOR for the costs incurred in returning the surplus material to the supplier.

SMALL HAND & POWER TOOLS:

No payment will be allowed for small hand and power tools which are not listed in the Rental Rate Blue Book for Construction Equipment as published by the Equipment Guide Book Company. All small hand and power tools listed in the Rental Rate Blue Book at a rate of less than one (1) dollar per hour will be considered part of overhead and will not be paid for separately.

EQUIPMENT:

For any machinery and equipment, including the foreman's transportation unit, which the OWNER approves for use on extra work

done by force account, the CONTRACTOR will be paid as follows:

The time paid for shall be the period that the equipment is required at the site of the extra work and, in addition, shall include traveling time to the location of the extra work when the equipment is moved under its own power. When transportation from one site to another is by other than its own power, the actual operating time during periods of loading and unloading will be paid for at the regular rental rate and transportation costs will be allowed.

When the periods of work are not consecutive and the interval between the termination of a period of work and the commencement of the subsequent period does not exceed thirty (30) days, the rates allowed will be the same as if the periods of work were consecutive.

The rental rate established for each piece of CONTRACTOR owned equipment, including appurtenances and attachments to equipment used will be determined by use of the Rental Rate Blue Book for Construction Equipment Volume 1, 2, or 3, as applicable. The edition which is current at the time the force account work was started will apply.

The established rental rate will be equal to the "Monthly" rate divided by 176; modified by the rate adjustment factor and the applicable map adjustment factor, plus the "Estimated Operating Costs per Hour", to which sum ten (10) percent will be added.

For equipment not listed in the Rental Rate Blue Book, Volume 1, 2, or 3, the rental rate will be determined by using the rate listed for a similar piece of equipment or by proportioning a rate listed so that the capacity, size, horsepower, and age are properly considered.

For equipment for which there are no comparable in the Rental Rate Blue Book, Volume 1, 2, or 3, the monthly rate shall be reasonable, but not more than five (5) percent of the current list price, or invoice, of the equipment. The base hourly rate shall then be determined by dividing the monthly rate by 176 to which sum twenty percent

(20%) will be added. The twenty percent (20%) includes adjustments and operating costs.

The rates used for CONTRACTOR owned trucks used to haul material will be those published by MDOT. These rates shall include all adjustments and operating costs. Separate payment for the driver will be allowed. The rates will be reviewed and adjusted periodically.

The rental rate for the foreman's transportation unit will be seven dollars (\$7.00) per hour, to which sum twenty percent (20%) will be added.

When leased or rented equipment is used on force account work, the hourly rate used in computation of payment will be the leased or rented rate, except that if the leased or rented rate exceeds the rental rate established by the Rental Blue Book, the established rate determined from the Blue Book will apply. In either case, the Estimated Operating Cost per Hour will be added to the appropriate hourly rate to which sum ten percent (10%) will be added.

In all cases the "Estimated Operating Cost per Hour" includes all fuel, oil, lubrications, tires, parts, and other operating expendables such as truck and labor assigned to the truck for servicing the equipment.

The rental rates allowed herein include the cost of insurance covering the usual insurable risks, including fire and theft. The OWNER will not be liable for losses which can be covered by insurance.

In the event that machinery or equipment is idled, payment may be allowed on a rental basis for the idled equipment as specified herein. Only machinery or equipment actually on the project site at the time of the delay, as required for that phase of construction work in question, will be considered eligible for rental reimbursement. Specialized equipment for machinery directly related to the work, whether on or off the site, may be considered eligible for payment if actually idled and if such idleness can be certified by the CONTRACTOR and verified by the

OWNER. Payment for idled equipment and/or machinery will not be allowed during periods of seasonal suspension of the work.

The rental rate for idled leased or rented equipment will be the leased or rented rate, or the equipment shall be returned and taken off rental as directed by the OWNER.

The rental rate for idled CONTRACTOR owned equipment will be the "Monthly" rate divided by 176; modified by the rate adjustment factor and the applicable map adjustment factor, and then multiplied by fifty percent (50%). No payment will be allowed for operating costs.

Payment will be limited to the difference between the hours worked and eight (8) hours in any one day and to the difference between the hours worked and forty (40) hours in any one week. No provisions of these specifications shall entitle the CONTRACTOR to rental compensation for idled equipment. No additional compensation for overhead will be allowed.

In the event that labor is idled, payment may be allowed provided there is no other location within the project that the labor can be gainfully employed. Payment will be limited to a maximum of eight (8) hours per occurrence and in no case will exceed the amount of the CONTRACTOR's obligation as provided by the CONTRACTOR's current labor agreement. No additional compensation for overhead will be allowed.

21. PAYMENTS WITHHELD

The OWNER may withhold or, on account of subsequently discovered evidence, nullify the whole or a part of any certificate for progress payment to such extent as may be necessary to protect itself from loss on account of:

Defective work not remedied;

Claims filed or reasonable evidence indicating probable filing of claims;

Failure of the CONTRACTOR to make payments properly to subcontractors or for material or labor;

A reasonable doubt that the Agreement can be completed for the balance then unpaid;

Damage to another CONTRACTOR.

When the above grounds are removed, payment shall be made for amounts withheld because of them.

22. USE OF COMPLETE PORTIONS OF THE WORK

The OWNER may, at any time during progress of the work, after written notice to CONTRACTOR, take over and place in service any completed portions of the work which are ready for service, although the entire work of the Agreement is not fully completed, and notwithstanding the time for completion of the entire work or such portions may not have expired. In such event, the CONTRACTOR will be relieved of further work on, or maintenance of, said portion except as covered by his guarantee of same.

Engineer Responsibilities

23. ENGINEER DURING CONSTRUCTION

The Work shall be subject to the approval of the ENGINEER, who shall determine the amount, quality, acceptability, and fitness of the items of work and materials to be furnished hereunder, and who shall decide all questions which may arise as to measurements of quantities and fulfillment of the requirements of the Contract Documents.

24. AUTHORITY & DUTIES OF CONSTRUCTION OBSERVER

Construction Observers may be appointed by the ENGINEER and directed to check or review materials used and completed work. The observation may extend to any parts of the Work and to the preparation or manufacture of the materials for use in the Work. Construction Observers will not be authorized to revoke, alter, enlarge, or relax any of the provisions of the Contract Documents. The Construction Observer will call to the attention of the CONTRACTOR any failure to follow the plans and

specifications that he may observe. In case of any dispute arising between the CONTRACTOR and Construction Observer as to materials furnished or the manner of performing the work, the Construction Observer shall have the authority to reject materials or completed items of work until the question at issue can be referred to and be decided by the ENGINEER. In no instance shall any action or omission on the part of the Construction Observer relieve the CONTRACTOR of the responsibility of completing the Work in accordance with the Contract Documents.

25. LIMITATIONS ON ENGINEER'S RESPONSIBILITIES

Neither ENGINEER's authority or responsibility under this Article or under any other provision of the Contract Documents nor any decision made by ENGINEER in good faith either to exercise or not exercise such authority or responsibility or the undertaking, exercise or performance of any authority or responsibility by ENGINEER shall create, impose or give rise to any duty owed by ENGINEER to CONTRACTOR, any subcontractor, any supplier, any other person or organization, or to any surety for or employee or agent of any of them.

ENGINEER will not supervise, direct, control or have authority over or be responsible for CONTRACTOR's means, methods, techniques, sequences or procedures of construction, or the safety precautions and programs incident thereto, or for any failure of CONTRACTOR to comply with laws and regulations applicable to the furnishing or performance of the Work. ENGINEER will not be responsible for CONTRACTOR's failure to perform or furnish the Work in accordance with the Contract Documents.

ENGINEER will not be responsible for the acts or omissions of CONTRACTOR or of any subcontractor, any supplier, or of any other person or organization performing or furnishing any of the Work.

ENGINEER's review of the final application for payment and accompanying

documentation and all maintenance and operating instructions, schedules guarantees, bonds and manufacturer's certificates of inspection, tests, and approvals and other documentation required in Article 14b will only be to determine generally that their content complies with the requirements of, and in the case of manufacturer's certificates of inspections, tests and approvals that the results certified indicate compliance with the Contract Documents.

The limitations upon authority and responsibility set forth in this Section shall also apply to ENGINEER's consultants, authorized representative and assistants.

26. LINES & GRADES

Principal reference lines or points and bench marks may be given by the ENGINEER at such time as he may deem necessary; or, if the CONTRACTOR shall be in need of such reference lines or bench marks, he shall notify the ENGINEER three (3) working days in advance.

The ENGINEER may set suitable stakes and marks showing locations and elevations of the various parts of the work, and will furnish the CONTRACTOR with required data referring to the reference points. No work shall be undertaken until such stakes and marks shall have been set by the ENGINEER. CONTRACTOR shall take due and proper precautions for the preservation of these stakes and marks, shall see that the work at all times proceeds in accordance therewith, and shall provide all labor and material to set the required line and grade control and locate the work accurately with reference to the above points. In case such stakes are destroyed due to the CONTRACTOR's carelessness, they will be replaced at the ENGINEER's earliest convenience and the CONTRACTOR may be back charged for the crew time incurred.

27. TESTING & SAMPLING

Where called for in the specifications, samples of materials in the quantity named shall be submitted to the ENGINEER for approval. Where tests are required, they

shall be made at the expense of the OWNER, except as otherwise called for in the specifications. For materials covered by ASTM or Federal Specifications, or with the specifications of well known or recognized technical and/or trade organizations, unless otherwise stipulated, required tests are to be made by the manufacturer, and his certificate therefore submitted to the ENGINEER.

The ENGINEER and/or OWNER shall determine which materials are required by the specifications to be factory certified or to have chemical or physical analysis or other examination or test. The CONTRACTOR shall furnish to the ENGINEER and/or OWNER two copies of orders for all materials requiring such examination or test as soon as placed. Such orders shall contain complete information, including that as to the quantity, quality, dimensions, sizes, capacities and types, shall contain proper reference to the applicable specifications by title, number and paragraph, and shall show the name and address of the producing factory but need not contain prices or contractual terms.

All materials and workmanship (if not otherwise designated by the specifications) shall be subject to examination and test by the ENGINEER and/or OWNER at any time during manufacture or construction, and at any place where such manufacture or construction is carried on. The ENGINEER and/or OWNER shall have the right to reject defective material and workmanship or require its correction. Rejected workmanship shall be satisfactorily corrected, and rejected material shall be satisfactorily replaced with proper material without charge therefore, and the CONTRACTOR shall promptly segregate and remove rejected material from the premises. If the CONTRACTOR fails to proceed at once with replacement of rejected material and correction of defective workmanship, the OWNER may, by Agreement or otherwise, replace such material and correct such workmanship and charge the cost thereof to the

CONTRACTOR, or may immediately terminate the Agreement.

CONTRACTOR shall furnish promptly, without additional charge, all reasonable facilities, labor and materials necessary for the safe and convenient conduct of all construction observations and tests that may be required by the ENGINEER. All construction observations and tests by the ENGINEER and/or OWNER shall be performed in such a manner as not to delay the work unnecessarily. Special, full size, and performance tests shall be as described in the specifications. CONTRACTOR shall be charged with any additional cost of construction observations when material or workmanship is not ready at the time checking is requested by the CONTRACTOR.

Should it be considered necessary or advisable by the ENGINEER and/or OWNER any time before final acceptance of the entire work to make an examination of work already completed, by removing or tearing out same, the CONTRACTOR shall on request promptly furnish all necessary facilities, labor and material. If such work is found to be defective or nonconforming in any material respect, due to the fault of the CONTRACTOR or his subcontractor, CONTRACTOR shall defray all the expenses of such examination and of satisfactory reconstruction, and be responsible for any resulting delay. If, however, such work is found to meet the requirements of the Agreement, the actual cost involved in the examination and replacement shall be allowed the CONTRACTOR and he shall in addition, if completion of the work has been delayed thereby, be granted a suitable extension of time on account of the additional work involved.

Examination of material and finished articles to be incorporated in the work at the site shall be made at place of production, manufacture or shipment stated in the specifications; and such examinations and acceptance, unless otherwise stated in the specifications, shall be final, except as

regards latent defects, departures from specific requirements of the Agreement and the specifications and drawings made a part thereof, damage or loss in transit, fraud or such gross mistakes as amount to fraud. Subject to requirements contained in the preceding sentence, examinations of material and workmanship for final acceptance as a whole or in part shall be made at the site.

Contractor Responsibilities

28. UNFORSEEN PHYSICAL CONDITIONS

CONTRACTOR shall promptly notify the OWNER and ENGINEER in writing of any subsurface or latent physical conditions at the site or in an existing structure differing materially from those indicated or referred to in the Contract Documents. The ENGINEER will promptly review those conditions and advise the OWNER in writing if further investigation or tests are necessary. Promptly thereafter, the OWNER shall obtain the necessary additional investigations and tests and furnish copies to the ENGINEER and the CONTRACTOR. If the ENGINEER finds that the results of such investigations or tests indicate that there are subsurface or latent physical conditions which differ materially from those intended in the Contract Documents, and which could not reasonably have been anticipated by the CONTRACTOR, a Change Order may be issued incorporating the necessary revisions.

29. COMPOSITION OF THE CONTRACTOR

If the CONTRACTOR hereunder is comprised of more than one legal entity, each such entity shall be jointly and severally liable hereunder.

30. ASSIGNMENT OF CONTRACT

The CONTRACTOR shall not sublet, assign or transfer this Agreement or any portion thereof or any payments due him thereunder, without the written consent of the OWNER.

Assignment or subletting the whole or any portion of this Agreement shall not operate

to release the CONTRACTOR or his bondsmen hereunder from any of the contract obligations.

The CONTRACTOR agrees that he is fully responsible to the OWNER for the acts and omissions of his subcontractors and of persons either directly or indirectly employed by him. Nothing contained in the Contract Documents shall create any contractual relation between any subcontractors and the OWNER.

Neither the ENGINEER nor any officer, agent or employee of the OWNER shall have any power or authority whatsoever to bind the OWNER or to incur obligation in his behalf to any subcontractors, material supplier or other persons in any manner whatsoever.

31. AGENTS

Work shall be carried on under personal supervision of the CONTRACTOR or his properly authorized representative, who shall be on the grounds at all times during the construction, and who shall have full and responsible charge of the Work with power to receive orders and carry out instructions.

32. SAFETY & PROTECTION

A. People and Property

CONTRACTOR shall be solely responsible for initiating, maintaining and supervising all safety precautions and programs in connection with the Work. CONTRACTOR shall take all necessary precautions for the safety of, and shall provide the necessary protection to prevent damage, injury or loss to:

All persons on the site or who may be affected by the Work;

All the Work and materials and equipment to be incorporated therein, whether in storage on or off the site; and

Other property at the site or adjacent thereto, including trees, shrubs, lawns, walks, pavements, roadways, structures, utilities, and Underground Facilities not designated for removal, relocation, or replacement in the course of construction.

B. Site Safety

CONTRACTOR shall comply with all applicable laws and regulations relating to the safety of persons or property, or to the protection of persons or property from damage, injury, or loss; and shall erect and maintain all necessary safeguards for such safety and protection. CONTRACTOR shall notify owners of adjacent property and of underground facilities and other utility owners when prosecution of the Work may affect them, and shall cooperate with them in the protection, removal, relocation, and replacement of their property. All damage, injury, or loss to any property referred to in this section caused, directly or indirectly, in whole or in part, by CONTRACTOR or any subcontractor, supplier, or any other individual or entity directly or indirectly employed by any of them to perform any of the Work, or anyone for whose acts any of them may be liable, shall be remedied by CONTRACTOR. CONTRACTOR's duties and responsibilities for safety and for protection of the Work shall continue until such time as all the Work is completed and ENGINEER has issued a notice to OWNER and CONTRACTOR that the Work is acceptable (except as otherwise expressly provided in connection with Substantial Completion).

C. Safety Representative

CONTRACTOR shall designate a qualified and experienced safety representative at the site whose duties and responsibilities shall be the prevention of accidents and the maintaining and supervising of safety precautions and programs.

D. Hazard Communication Program

CONTRACTOR shall be responsible for coordinating any exchange of material safety data sheets or other hazard communication information required to be made available to or exchanged between or among employers at the site in accordance with laws or regulations.

E. Compliance with MIOSHA

All of the CONTRACTOR and subcontractors operations and construction equipment shall comply with requirements of the Michigan Occupational Safety and Health Act (MIOSHA) insofar as they apply to the work to be performed under this Contract.

33. CONTRACTOR'S SUPERVISION & ORIGINATION

The Work under this Agreement shall be under the direct supervision and direction of the CONTRACTOR. The CONTRACTOR shall give sufficient supervision to the Work, using his best skill and attention. The CONTRACTOR shall, at all times, keep on the site of the Work during its progress a competent superintendent and any and all necessary foremen and assistants. The superintendent shall represent and have full authority to act for the CONTRACTOR in the latter's absence, and all directions given to him shall be as binding as if given to the CONTRACTOR. On written request in each case, all such directions will be confirmed in writing to the CONTRACTOR.

The CONTRACTOR shall employ only competent, efficient workmen and shall not use on the Work any unfit person or one not skilled in the work assigned to him, and he shall at all times enforce strict discipline and good order among his employees. Whenever the ENGINEER shall notify the CONTRACTOR, in writing, that any man on the Work is, in the opinion of the ENGINEER, careless, incompetent, disorderly, or otherwise unsatisfactory, such man shall be discharged from the work and shall not again be employed on it except with the written consent of the ENGINEER.

The CONTRACTOR shall establish and maintain an office on the site of the work, or at some convenient point adjacent thereto, during the continuance of this Agreement and shall have at all times during working hours, a representative authorized to receive and execute any and all orders, when given by the ENGINEER; and such order, when given out and received by said representative shall be deemed to have been

given to and received by the CONTRACTOR. Copies of the drawings and specifications shall at all times be kept on file by the CONTRACTOR at readily accessible points near the work.

34. CONTRACTOR'S RIGHT TO STOP WORK

If the work should be stopped under an order of any court, or other public authority for a period of three months, through no act or fault of the CONTRACTOR or of anyone employed by him, or if the OWNER should fail to pay to the CONTRACTOR within sixty (60) days of its maturity and presentation any sum certified by the ENGINEER, provided no appeal is taken, the CONTRACTOR may, upon seven (7) days' written notice to the OWNER and the ENGINEER, stop work or terminate this Agreement, and shall receive from the OWNER payment in full for all work executed, as determined from the prices contained in the approved detailed estimate as computed by the ENGINEER, but no claim for extra compensation or damages shall be made or allowed because of such termination of the Agreement.

35. STORAGE OF MATERIALS

Materials and equipment distributed, stored and placed upon or near the site of the Work shall at all times be so disposed as not to interfere with work being prosecuted by other contractors in the employ of the OWNER, or with street drainage, or with fire hydrants or with access thereto, and not to hinder any more than may be necessary the ordinary traffic (either vehicular or pedestrian) of the street.

36. CLEANING UP

The CONTRACTOR shall, as directed by the ENGINEER, remove at his own expense from the OWNER's property and from all public and private property all temporary structures, rubbish and waste materials resulting from his operations. This requirement shall not apply to property used for permanent disposal of rubbish or waste materials in accordance with permission of

such disposal granted to the CONTRACTOR by the OWNER thereof.

37. SUNDAY & NIGHT WORK

The CONTRACTOR is required to prosecute work done under this Agreement during the hours of daylight, and no work will be permitted at night or on Sundays, except to save property or life, or as specifically authorized or directed by the ENGINEER.

No work shall be permitted on holidays.

38. SANITARY REGULATIONS

Sanitary conveniences for the use of project personnel properly secluded from public observation shall be constructed and maintained in sanitary condition by the CONTRACTOR. Its use shall be strictly enforced.

39. PERMITS & REGULATIONS

The CONTRACTOR shall secure, at no cost to the OWNER, all permits and licenses necessary for the prosecution of the Work. He shall pay for same at his own expense as well as for any inspection fees required in connection with such permits, and shall conduct his operations in accordance with the provisions of such permits, including tunneling of pavements where required. He shall also furnish any required bonds and pay the cost of same.

The CONTRACTOR shall keep himself fully informed of all laws, ordinances, and regulations in any manner affecting those engaged or employed in the Work or materials used in the Work, or in any way affecting the conduct of the Work, and of all orders and decrees of bodies or tribunals having any jurisdiction or authority over the same.

He shall at all times observe and comply with, and shall cause all his agents and employees to observe and comply with all existing and future laws, ordinances, regulations, orders and decrees; provided, that if the drawings and specifications are at variance therewith, the CONTRACTOR shall promptly notify the ENGINEER in

writing and any necessary changes shall be adjusted as provided in the Contract Documents.

All work shall be executed and checked in accordance with all local and state rules and regulations and all established codes applicable thereto and shall conform in all respects to the requirements of all competent authorities having jurisdiction there over.

Should any change in plans and specifications be required to comply with local regulations, CONTRACTOR shall notify the OWNER at the time of submitting his bid. After entering into Agreement, CONTRACTOR will be held to complete the work necessary to meet local requirements without extra expense to the OWNER.

Where the work required by the drawings and specifications is above the standard required, it shall be done as shown or specified.

40. GUARANTEE

The CONTRACTOR, as a condition precedent to final payment, shall execute a guarantee to the OWNER warranting for a period of two (2) years from date of final payment to keep in good order and repair any defect in all the work done under the Agreement, either by the CONTRACTOR, his subcontractors, or material suppliers, that may develop during said period due to improper materials, defective equipment, improper materials workmanship, or arrangements, and any other work affected in making good such imperfections shall also be made good, all without expense to the OWNER, and CONTRACTOR shall execute, in favor of the OWNER the attached Maintenance and Guarantee Bond.

41. PATENTS

CONTRACTOR shall pay all royalties and license fees and shall hold and save the OWNER and his agents harmless from all liability of any nature or kind, including cost and expenses for, or on account of, any patented or unpatented invention, process, article or appliance manufactured or used in

performance of the Agreement, including its use by the OWNER, unless otherwise specifically stipulated in the Contract Documents. In this respect the CONTRACTOR shall defend all suits or claims for infringement of any patent or license right.

In the event that any claim, suit or action at law or inequity of any kind whatsoever is brought against the OWNER, involving any such patents or license rights, then the OWNER shall have the right to, and may retain, from any money due or to become due to the CONTRACTOR, such sufficient sum as is considered necessary to protect said OWNER against loss, and such sum may be retained by the OWNER until such claim or suit shall have been settled and satisfactory evidence to that effect shall have been furnished the OWNER.

42. INFORMATION BY THE CONTRACTOR

The CONTRACTOR shall submit to the ENGINEER full information as to the materials, equipment and arrangements that the CONTRACTOR proposes to furnish. This information shall be complete to the extent that the ENGINEER may intelligently judge if the proposed materials, equipment and arrangements will meet with the requirements of the Contract Documents.

Prior to approval of the materials, equipment and arrangements by the ENGINEER, based on the information submitted by the CONTRACTOR, any work done by the CONTRACTOR shall be at his own risk.

Approval of information covering materials, equipment and arrangements by the ENGINEER shall in no way release CONTRACTOR from his responsibility for the proper design, installation and performance of any material, equipment or arrangement, or from his liability to replace same should it prove defective.

43. FORFEITURE OF CONTRACT

If work to be done under the Contract Documents shall be abandoned by CONTRACTOR or if, at any time in the

judgment of the OWNER, CONTRACTOR shall fail to prosecute the Work at a reasonable rate of progress, or to comply with all or any of the terms and requirements herein set forth, then the OWNER shall have the right to take possession of the Work, including CONTRACTOR's plant, supplies and materials, at any time after having notified the CONTRACTOR, in writing, to discontinue work under this Agreement for said cause or causes, and such action shall not affect the right of the OWNER to recover damages resulting from such failure. Upon receiving such notice the CONTRACTOR shall and will, upon demand, immediately give the OWNER safe and peaceable possession of the Work, including the plant, and shall then cease to have control over any portion thereof or the men employed thereon.

The OWNER may then proceed to complete the Work herein specified, by Agreement or otherwise; and the entire cost of same shall be charged to the CONTRACTOR and deducted from any sum or sums due or to become due under the Agreement; the excess cost, if any, to be paid by CONTRACTOR or his sureties to said OWNER.

44. RELATION TO OTHER CONTRACTORS

CONTRACTOR shall so conduct his operations as not to interfere with or injure the work of other contractor's or workmen employed on adjoining or related work, and he shall promptly make good any injury or damage which may be done to such work by him or his employees or agents. Should a contract for adjoining work be awarded to another contractor, and should the work of one of these contracts interfere with that of the other, the OWNER shall decide which contractor shall cease work for the time being and which shall continue, or whether work in both contracts shall continue at the same time and in what manner.

45. "OR EQUAL" CLAUSE

Whenever, in any of the Contract Documents an article, material or equipment

is defined by describing a proprietary product or by using the name of a manufacturer or vendor, the term "or equal", if not inserted, shall be implied. The specific article, material or equipment mentioned shall be understood as indicating the type, function, minimum standard of design, efficiency and quality desired, and shall not be construed in such a manner as to exclude manufacturers' products of comparable quality, design and efficiency. If the CONTRACTOR proposes any "or equal" substitutes, these substitutes shall be subject to the review and approval of the OWNER before they can be incorporated into the work.

Legal

46. INDEMNIFICATION

To the fullest extent permitted by Laws and Regulations, CONTRACTOR shall indemnify and hold harmless OWNER and ENGINEER and their consultants, agents and employees from and against all claims, damages, losses and expenses, direct, indirect or consequential (including but not limited to fees and charges of engineers, architects, attorneys and other professionals and court and arbitration costs) arising out of or resulting from the performance of the Work, provided that any such claim, damage, loss or expense (a) is attributable to bodily injury, sickness, disease or death, or to injury to or destruction of tangible property (other than the Work itself) including the loss of use resulting therefrom and (b) is caused in whole or in part by any negligent act or omission of CONTRACTOR, any subcontractors, any person or organization directly or indirectly employed by any of them to perform or furnish any of the Work or anyone for whose acts any of them may be liable, regardless of whether or not it is caused in part by a party indemnified hereunder or arises by or is imposed by Law and Regulations regardless of the negligence of any such party.

In any and all claims against OWNER or ENGINEER or any of their consultants,

agents or employees by any employee of CONTRACTOR, any subcontractors, any person or organization directly or indirectly employed by any of them to perform or furnish any of the Work or anyone for whose acts of them may be liable, the indemnification obligation under the preceding paragraph shall not be limited in any way by any limitation on the amount or type of damages, compensation or benefits payable by or for CONTRACTOR or any such subcontractors or other person or organization under worker's or workmen's compensation acts, disability benefit acts or other employee benefit acts.

The obligations of the CONTRACTOR under this article shall not extend to the liability of ENGINEER, ENGINEER's consultants, agents or employees arising out of the preparation or approval of drawings, opinions, reports, surveys, change orders, designs or specifications.

47. CONTROLLING LAW

In the case of a legal dispute between the OWNER and the CONTRACTOR the law of the state of Michigan shall govern. The venue for resolving any legal dispute between the two parties will be within the County of the OWNER's legal address.

48. NO WAIVER OF CONTRACT

Neither acceptance of the whole or any part of the Work by the OWNER or his ENGINEER, or any of its agents, nor any order, measurements or certificate by the ENGINEER, nor any order by OWNER for payment of money, nor any payment for the whole or any part of the Work by OWNER, nor any extension of time, nor any possession taken by the OWNER or its agents, shall operate as a waiver for any portion of the Contract Documents or any power therein provided; nor shall any waiver

of any breach of contract be held to be a waiver of any other or subsequent breach.

49. DISPUTE RESOLUTION

Dispute resolution methods and procedures, if any, shall be as set forth in the Supplemental Specifications. If no method and procedure has been set forth, OWNER and CONTRACTOR may exercise such rights or remedies as either may otherwise have under the Contract Documents or by Laws or Regulations in respect of any dispute.

50. GIVING NOTICE

Whenever any provision of the Contract Documents requires the giving of written notice, it will be deemed to have been validly given if delivered in person to the individual or to a member of the firm or to an officer of the corporation for whom it is intended, or if delivered at or sent by registered or certified mail, postage prepaid, to the last business address known to the giver of the notice.

51. CUMULATIVE REMEDIES

The duties and obligations imposed by these General Conditions and the rights and remedies available hereunder to the parties hereto are in addition to, and are not to be construed in any way as a limitation of, any rights and remedies available to any or all of them which are otherwise imposed or available by Laws or Regulations, by special warranty or guarantee, or by other provision of the Contract Documents, and the provisions of this paragraph will be as effective as if repeated specifically in the contract Documents in connection with each particular duty, obligation, right, and remedy to which they apply.

End of Section

GENERAL SPECIFICATIONS

Table of Contents

1.	Existing Underground Structures & Utilities.....	1
2.	Soil Conditions.....	1
3.	Soil Erosion and Sedimentation Control	1
4.	Preservation, Protection & Use of Survey Controls, Monument Points & Grade Stakes	2
5.	Protection of Public and Private Utilities.....	2
6.	Miscellaneous Damages	3
7.	Sump Pump Discharge Pipe & Local Services.....	3
8.	Existing Sewer Facilities.....	3
9.	Existing Water Facilities	3
10.	Existing Gas Facilities.....	3
11.	Existing Electric, Cable, and Telecommunications	3
12.	Preservation of Trees & Shrubbery....	4
13.	Trimming Trees & Shrubs.....	4
14.	Maintenance of Service	4
15.	Cleanliness of the Work Site and Streets	4
16.	Dust Control	5
17.	Working Space & Use of Streets or Private Property	5
18.	Easements.....	5
19.	Power & Light.....	5
20.	Water	5
21.	Weather Protection & Heating	6
22.	Railroad Crossing.....	6
23.	Ownership of Salvaged Materials	6

1. EXISTING UNDERGROUND STRUCTURES & UTILITIES

The location of public or private utilities shown on the plans is in accordance with the best information available. No guarantee is given that the locations are absolutely accurate or that utilities other than those shown are not present.

For protection of underground utilities, the CONTRACTOR shall contact “MISS DIG” at 1-800-482-7171 a minimum of three (3)

working days prior to excavating. This does not relieve the CONTRACTOR of the responsibility of notifying utility OWNERS who may not be part of the “MISS DIG” alert system.

2. SOIL CONDITIONS

If soil borings have been taken for this project, then they are included in an appendix.

Where the OWNER has caused soil borings to be made to aid the ENGINEER in design of the work, these boring logs are provided herein for the prospective bidder to examine. This information is given to bidders as an aid in determining the character of the soil and groundwater conditions. The OWNER does not guarantee that the ground encountered during construction will conform to the borings. Bidders should secure such other information as they consider necessary to check and supplement the above data.

The CONTRACTOR shall complete the work in whatever materials, and under whatever conditions he may encounter or create.

3. SOIL EROSION AND SEDIMENTATION CONTROL

The CONTRACTOR shall comply with the requirements of the Soil Erosion and Sedimentation Control Act of the State of Michigan, Part 91 of ACT 451 of PA of 1994 and with all the requirements, rules and standards of the official enforcing agent for the project location.

If a soil erosion control permit is required on this project, the CONTRACTOR shall adhere to the specific conditions of the project permit. Where the permit is issued in the name of the CONTRACTOR and requires that a bond be posted, the

CONTRACTOR shall include in his bid the permit fee and bond expense.

The ENGINEER shall have full authority to require compliance with the soil erosion control requirements and may order suspension of the work if measures are not adequate or a problem develops requiring additional soil erosion control measures. Any ordered suspension of the work shall not be grounds for CONTRACTOR's claims for "down time" or "lost time".

4. PRESERVATION, PROTECTION & USE OF SURVEY CONTROLS, MONUMENT POINTS & GRADE STAKES

During the progress of the work, the CONTRACTOR may encounter section line, fractional section line, and property controlling corner monuments. Insofar as is known, such public land survey corners and property monuments have been indicated on the plans.

The CONTRACTOR shall be responsible for complying with the requirements of Michigan Public Act 34. Specifically, he shall be responsible for notifying the county surveyor before removing a public land survey corner monument for construction activities. In addition, if construction time constraints will result in the public land survey corner monument being removed for more than one year, then the CONTRACTOR shall arrange to have a temporary corner monument set until the permanent one can be re-established. The costs of removing and replacing public land survey corner monuments as well as setting temporary corner monuments shall be the responsibility of the CONTRACTOR unless pay items are provided in the bid form for these tasks. The CONTRACTOR shall not remove any such monument until the ENGINEER has witness points as reference for resetting of such monuments. After referencing has been done and suitable permanent sketches prepared, the ENGINEER will give permission to the

CONTRACTOR for removal of the monument. Monuments and monument boxes shall be reset only after all backfilling has fully settled.

The CONTRACTOR shall protect and preserve all monument points, property corners, grade stakes, line and reference points. Where stakes and markers are disturbed or removed due to operations under this Contract, the CONTRACTOR shall be charged at invoice cost by the ENGINEER for replacing the points. Care shall be exercised by the CONTRACTOR when operating near the markers, as any carelessness in operations will also cause a time delay to the schedule due to additional stakeout time required to replace reference points, lines, etc.

The CONTRACTOR shall accurately locate the work from reference points established by the ENGINEER along the surface of the ground and line of work.

5. PROTECTION OF PUBLIC & PRIVATE UTILITIES

Where any utility, water, sewer, gas, telephone or any other public or private utilities are encountered, the CONTRACTOR must provide adequate protection for them, and he will be held responsible for any damages to such utilities arising from his operations.

When it is apparent that construction operations may endanger the foundation of any utility, conduit, or support of any structure, the CONTRACTOR shall notify the utility OWNER of this possibility, and he shall take such steps as may be required to provide temporary bracing or support of conduits or structures.

In all cases where permits or inspection fees are required by utilities in connection with changes to or temporary support of their conduits, the CONTRACTOR shall secure permits and pay all inspection fees.

When it is necessary in order to carry out the work that a pole, telephone or electric, be moved to a new location or moved and replaced after construction, the CONTRACTOR shall arrange for moving such pole or poles and the lines thereof, and shall pay any charges.

Where it is the policy of any utility owner to make his own repairs to damaged conduit or other structures, the CONTRACTOR shall cooperate to the fullest extent with the utility OWNER and shall see that his operations interfere as little as possible with the utility OWNER's operations.

6. MISCELLANEOUS DAMAGES

The CONTRACTOR shall be responsible for repairing all damages to existing lawns, sidewalk, parking lots, streets or other areas outside the limits of the Contract. Private utilities, private ornamental gas or electric lights, sprinkler systems, fences, shrubs, trees, existing sidewalk, or any other surface or subsurface items of value damaged by the CONTRACTOR shall be repaired, replaced or removed and replaced to at least equal condition at the CONTRACTOR's expense unless otherwise specified on the plans.

7. SUMP PUMP DISCHARGE PIPE & LOCAL SERVICES

Any discharge pipe from sump pumps or yard drains encountered on this project, whether or not shown on the plans, which discharges to existing ditches and/or storm sewers or cross public or private easements, shall be maintained, replaced, or reconnected as necessary. Bulkheads shall be placed only as approved by the Engineer. Sump pump connections shall be made to the storm drain pipe by a coring method as approved by the ENGINEER. The CONTRACTOR shall use adequate measures to prevent soil erosion, sedimentation, and/or ponding when connecting discharge pipes to existing or proposed ditches. This work shall be

considered as incidental to the cost of the project.

8. EXISTING SEWER FACILITIES

Existing sewers or drains may be encountered along the line of work. In all such cases, the CONTRACTOR shall perform his operation in such a manner that sewer service will not be interrupted. He shall, at his own expense, make all temporary provisions to maintain sewer service.

Unless otherwise indicated on the plans, the CONTRACTOR shall replace, at his own expense, any disturbed sewer or drain, or relay same at a new grade to be established by the ENGINEER such that sufficient clearance for the sewer will be provided.

9. EXISTING WATER FACILITIES

Where existing water mains and/or water services are encountered in the work, they shall be maintained in operation. They shall be relayed if necessary using the class of pipe and fittings standard to the OWNER of the main.

10. EXISTING GAS FACILITIES

Where existing gas mains are encountered, the CONTRACTOR shall immediately notify the ENGINEER and the gas company. The CONTRACTOR shall then arrange with the gas company for any necessary relocation. The CONTRACTOR will receive no extra compensation on account of delays incurred in conjunction with such relocations.

11. EXISTING ELECTRIC, CABLE, AND TELECOMMUNICATIONS

Where existing electric, cable, or telecommunications facilities are encountered, the CONTRACTOR shall immediately notify the ENGINEER and the affected utility company(ies). The CONTRACTOR shall then arrange with the

utility company for any necessary relocation. The CONTRACTOR will receive no extra compensation on account of delays incurred in conjunction with such relocations.

12. PRESERVATION OF TREES & SHRUBBERY

No trees or shrubbery of any kind shall be removed or destroyed by the CONTRACTOR without written permission of the ENGINEER. The CONTRACTOR will be held fully responsible for any damages caused by his work to adjoining trees and shrubs. Ample precautions shall be taken by the CONTRACTOR to protect such trees and shrubs that are to remain in place by surrounding them with fences or other protection before construction begins. Shrubbery that must be removed shall be preserved and replaced in a manner acceptable to the OWNER.

The CONTRACTOR shall protect and/or replace all shrubbery damaged or destroyed by operations under this Contract. The CONTRACTOR shall receive no extra compensation for preservation of trees and shrubbery.

13. TRIMMING TREES & SHRUBS

Where necessary in the field, the CONTRACTOR shall trim trees and shrubs by a method approved by the ENGINEER. All cut surfaces over one inch in diameter shall be painted with grafting wax. All branches which have been damaged by construction shall be pruned correctly to branch collars, to help promote the health of the tree. Also, any abrasions or gouges afflicted on the tree trunks during construction should be bark traced and lightly coated with tree paint. This work shall be incidental to the project.

14. MAINTENANCE OF SERVICE

Drainage through existing sewers, ditches and drains shall be maintained at all times

during construction, and all nearby gutters shall be kept open for drainage. Where existing sewers are encountered in the line of work that interfere with construction, the flow in the sewers, including both dry weather flow and storm flow, shall be maintained.

During the progress of the work, the CONTRACTOR shall accommodate both vehicular and foot traffic and shall provide free access to fire hydrants, water and gas valves. Except as otherwise specified herein or as noted on the plans, street intersections may be blocked but one-half at a time, and Contractor shall lay and maintain temporary driveways, bridges and crossings such as are necessary, in the opinion of the ENGINEER, to reasonably accommodate the public.

In the event detours, traffic control devices or safety equipment are needed, they shall be placed and maintained in accordance with the Michigan Manual of Uniform Traffic Control Devices (MMUTCD).

Maintenance of service as described above shall be considered as incidental to the project cost unless pay items have been included in the proposal for this work.

15. CLEANLINESS OF THE WORK SITE & STREETS

The CONTRACTOR shall keep the work site and all property occupied by him in a neat and orderly condition at all times. Waste material, rubbish and debris shall not be allowed to accumulate. The CONTRACTOR's equipment, temporary buildings and excess materials shall be promptly removed from the work site when no longer needed. At completion of the work, the premises shall be left clean.

The CONTRACTOR shall keep the streets clean. Trucks hauling excavated material, cement, sand, stone or other loose materials from or to the site shall be tight so that no spillage will occur on adjacent streets. Before trucks start away from the site, their

loads shall be trimmed and covered. If, in the judgment of the OWNER, adequate cleanup efforts are not being expended, including but not limited to, roadway, driveway and drainage maintenance, and removal of surplus materials, further construction shall be halted and work forces directed to the cleanup activity until proper order is restored. Should the CONTRACTOR continue to be negligent of his duties in maintaining proper street cleanliness, the OWNER will take necessary steps to perform such cleaning and shall charge the CONTRACTOR for all the costs.

16. DUST CONTROL

All haul roads, detour roads, temporary access roads, other public or private roads, driveways and parking lots used by the CONTRACTOR must be maintained in a dust free condition for the duration of the Contract. The control of the dust shall be accomplished by application of dust control materials and methods of application as approved and as directed by the ENGINEER. Such dust control materials shall be applied as often as is necessary to control dust. Neglect of dust control will not be tolerated.

Should the CONTRACTOR be negligent of his duties in providing dust control, the OWNER may, with or without notice cause the same to be done and deduct the cost of such work from any monies due or to become due the CONTRACTOR under the Contract. Cost of providing dust control shall be considered incidental to the project.

17. WORKING SPACE & USE OF STREETS OR PRIVATE PROPERTY

The CONTRACTOR's operations in public streets or alleys shall be confined to as small a space as practicable, so as not to cause undue inconvenience to the public or abutting properties, and shall be subject to the approval of the ENGINEER.

Where the CONTRACTOR wishes to work on or stockpile materials on nearby properties, it will be his responsibility to contact the property owner for permission. Upon request, the CONTRACTOR shall provide a copy of written permission from any affected property owner. The OWNER will not become involved with any such agreements and will not be held responsible for any damages that the CONTRACTOR may cause to private property. The CONTRACTOR shall not be compensated for restoration of private properties and stockpile areas unless said areas were within the original project limits.

18. EASEMENTS

Prior to the start of construction, the CONTRACTOR shall verify with the OWNER that any required easements have been obtained.

The CONTRACTOR shall keep his work operations within these easements and shall be responsible for complying with any easement conditions that are shown on the plans or stated in the Contract documents.

19. POWER & LIGHT

The CONTRACTOR shall furnish, at his own expense, all the electric power and lighting necessary during the life of this Contract or until such time as the OWNER takes over the work. The CONTRACTOR shall be responsible for complying with any applicable ordinances or regulations concerning power and light.

20. WATER

Unless otherwise allowed by the OWNER, the CONTRACTOR shall furnish, at his own expense, all the water necessary during the life of this Contract or until such time as the OWNER takes over the work.

The CONTRACTOR shall not make a connection to any public water main or fire

hydrant without first obtaining the necessary permit and/or meter from the OWNER.

Existing public water systems shall be operated and controlled by the OWNER. All valves shall be operated exclusively by the OWNER's personnel.

The CONTRACTOR shall not make any connection to or obtain water from a private water source without obtaining written permission from the owner of the water source. The CONTRACTOR shall provide a copy of the written permission to the OWNER upon request.

21. WEATHER PROTECTION & HEATING

The CONTRACTOR shall provide and maintain weather protection and heating at his own expense to properly protect the work under construction from damage if weather conditions require. This work shall include all windbreaks, insulating cover, and other necessary measures required to provide protection from freezing.

The CONTRACTOR shall continue to provide weather protection and heating as necessary until such time as the OWNER takes over the work.

22. RAILROAD CROSSING

Where the work crosses a railroad right-of way, the CONTRACTOR shall secure Railroad Company approval of his methods and schedule of operation. The CONTRACTOR shall carry out his work in strict accordance with the standards of the Railroad Company. The CONTRACTOR shall pay any inspection, signal or flagman costs.

23. OWNERSHIP OF SALVAGED MATERIALS

All salvageable materials such as castings, hydrants, valves, culverts and similar items removed during construction shall remain

the property of the OWNER. The CONTRACTOR shall deliver these salvaged materials to the OWNER's public works facility. If the OWNER indicates that he does not want the salvaged items, then the CONTRACTOR shall be responsible for disposal of the items.

End of Section

EARTHWORK

Table of Contents

General

- 1. Scope of Work.....1
- 2. MDOT.....1

Materials

- 3. Bedding1
- 4. Backfill.....2
- 5. Stone Refill.....2
- 6. Embankment2

Construction

- 7. Clearing2
- 8. Tree Removal2
- 9. Stump Removal.....2
- 10. Pavement Cuts.....2
- 11. Classification of Excavation3
- 12. Roadway Earthwork.....3
- 13. Methods of Excavation in Earth.....3
- 14. Trench Excavation3
- 15. Transport of Native Materials Offsite...4
- 16. Stone Refill for Trench Undercut.....4
- 17. Excavation & Trench Dewatering.....4
- 18. Diverting Existing Sewers.....5
- 19. Sheet piling, Bracing & Shoring5
- 20. Sheet piling Left in Place5
- 21. Crossing Existing Structures/Pipes6
- 22. Tunneling Trees6
- 23. Backfilling.....6
- 24. Placing and Compacting Embankment.8
- 25. Disposal of Excavated Material8
- 26. Final Cleanup & Grading8
- 27. Contractor Safety Requirements9

GENERAL

1. SCOPE OF WORK

This work shall be subject to the General Conditions and the General Specifications. The work shall include furnishing of labor,

materials, tools, equipment, accessories and services necessary for completing the excavation and backfilling for the items as shown on the contract drawings and/or as herein required. This also includes trenching, trench or subgrade undercutting, roadway earthwork, complete and continual drainage of excavation, sheet piling, bracing and shoring of sides of the excavation, backfilling around structures and over pipelines, and the disposal of excess excavated material.

2. MDOT

References to Michigan Department of Transportation (MDOT) Specifications shall pertain to the 2020 Standard Specifications for Construction.

MATERIALS

3. BEDDING

- A. Sand shall be a sharp, clean sand free of lumps of clay or debris with 100 percent passing a 3/8-inch sieve and less than 10 percent loss by wash.
- B. Granular material shall meet the requirements of Section 902.07 of the MDOT Standard Specifications for Construction for Granular Material Class II and Class III.
- C. Pea gravel shall be unwashed and shall be from 1/4-inch to 5/8-inch in size.
- D. Bedding material shall be provided from offsite unless the trench passes through a well-defined strata of sand or gravel. Bedding material shall be subject to the approval of the ENGINEER.
- E. Stone material shall meet the requirements of Section 902.03 of the MDOT Standard Specifications for

Construction for 6A crushed Coarse Aggregate or approved equal.

4. BACKFILL

A. Job Excavated Backfill

Job excavated backfill shall be defined as material excavated from the site that is free from frozen earth, boulders, rocks, stones larger than 3-inch in size, debris, blue and gray clay, and organic material.

B. Granular Backfill

Granular backfill shall be defined as sharp sand, gravel, or crushed stone that is free from lumps of clay and soft or flaky material and shall conform to the latest MDOT Specification for Granular Material Class II or III. Granular backfill shall be used for fill work located under or within the influence of roadway surfaces. The Owner's standard details shall dictate which type of granular material (class II or III) is required for the project.

Material excavated from the trench may be used as granular backfill when, in the opinion of the ENGINEER, it meets the granular backfill grading requirements.

5. STONE REFILL

Stone refill shall consist of natural gravel, slag, or crushed gravel that is equivalent in gradation to MDOT 6A unless otherwise called for in the plan details.

6. EMBANKMENT

Embankment material shall consist of sound earth as described in Section 205.03H of the MDOT Standard Specifications for Construction.

CONSTRUCTION

7. CLEARING

Prior to the start of construction, the CONTRACTOR shall verify the limits of trees and other items that are to be saved. The CONTRACTOR shall then clear the site or trench excavation area of all remaining trees, brush, and other miscellaneous items that are not to be saved.

8. TREE REMOVAL

Where called for on the plans, the CONTRACTOR shall remove trees, including stump and main roots, and dispose of all associated foliage and debris offsite. Trees less than six (6) inch diameter shall be removed where required by the Work as incidental to the Contract. The CONTRACTOR shall abide by any easement agreements regarding the tree removal work and wood ownership.

9. STUMP REMOVAL

Where called for on the plans, the CONTRACTOR shall remove existing stumps, including main roots (two (2) inch diameter and larger), dispose of all associated debris offsite, and backfill the void with suitable material.

10. PAVEMENT CUTS

Where a trench must be cut through pavement, driveway, or sidewalk, particular care shall be taken to avoid unnecessary damage to adjoining areas of the pavement, driveway or sidewalk. All cuts through existing surfaces shall be made full-depth with a concrete saw. Cuts in concrete pavement shall be made parallel with longitudinal and transverse construction or contraction joints.

Saw cuts in concrete pavement shall not be nearer than five feet (5'-0") to a transverse joint, to the centerline of pavement, or to the edge of pavement or curb, i.e., no existing or replacement pavement shall be less than five feet (5'-0") in width. If the damaged pavement or surfacing is nearer than five feet (5'-0") to a joint or centerline of

pavement, or to edge of pavement, surfacing or curb, removal and replacement shall be extended to said joint, centerline, edge of pavement, surfacing, or curb. These same requirements shall apply to the saw cutting and replacement of concrete driveways.

If a square or block of sidewalk is cut, broken, or cracked, the entire square or block shall be removed and replaced.

11. CLASSIFICATION OF EXCAVATION

Earth, as a name for excavated material, shall include all glacial deposits whether cemented or not, except solid boulders one-half cubic yard or more in volume. It shall also include all alluvial deposits and material of every kind that can be excavated with equal facility by the equipment and means typically used for earth excavation.

Peat, as a name for excavated material, shall include all unstable organic soils such as peat, muck, marl, and underlying very soft clay.

Rock, as a name for excavated material, shall include pre-glacial solid ledge rock that can be removed most practically by blasting, barring or wedging, or by some other standard method of quarrying solid rock. It shall also include solid boulders of one-half cubic yard or more in volume as well as existing concrete, masonry with mortar joints, or other existing structural work that can be excavated practically only by methods of quarrying solid rock. It shall not include fragile, friable, or disintegrated materials of any kind that can be excavated by equipment and means used for earth excavation.

12. ROADWAY EARTHWORK

Roadway earthwork shall be performed in accordance with the construction methods that are described in Section 205 of the MDOT Standard Specifications for Construction unless otherwise called for in

the plan notes, details, or supplemental specifications.

13. METHODS OF EXCAVATION IN EARTH

All excavation shall be by open cut from the surface, except in special cases where boring/jacking under pavement or structures may be required, or where boring/jacking under the root system will be required for tree root protection. All excavation shall be made in such a manner and to such depth, length, and width as will give ample room for building the structures, bracing, sheeting and supporting the sides of the excavation, pumping and drainage of ground water and sewage which may be encountered, and removal of all materials excavated. Special care shall be taken so that the soil below the bottom of structures to be built shall be left undisturbed so that a firm bed will be provided for construction. Any voids shall be backfilled with suitable granular material and shall be properly compacted.

14. TRENCH EXCAVATION

A. General

Excavation shall be of sufficient width and depth to provide adequate room for construction and installation of the work to the lines, grades and dimensions called for on the plans. Unless otherwise called for on the OWNER's standard details, the width of a trench from the invert to a height twelve (12) inches above the top of the pipe barrel shall be indicated as follows:

Pipe Size	Maximum Trench Width
4" through 12"	30"
Larger than 12"	O.D. + 24"

If the maximum trench width as specified above is exceeded, unless otherwise shown on the drawings, the CONTRACTOR shall install, at his own expense, such concrete

cradling or other bedding as is approved by the ENGINEER, to support the added load of the backfill.

Where trench excavation is in granular material, the last six (6) inches of trench depth shall be carefully excavated and trimmed by hand to the exact elevation and contour of pipe. Where trench excavation is in rock or clay soil, the trench bottom shall be undercut a minimum of four (4) inches below the final elevation of pipe. The bedding material as hereinafter specified shall be placed and compacted to the underside of the pipe.

Excavation for structures shall be made to the outside lines and surfaces of such structures wherever it is practicable to build directly against the sides and bottoms of excavations. In such cases, care shall be taken not to disturb the original foundation or backing. Final trimming shall be done by hand just before construction of the structure. If excess excavation is made, or the material becomes disturbed so as to require removal beyond the prescribed limits, the resulting space shall be refilled with bedding, as specified hereinafter, and solidly machine tamped into place to 95 percent of maximum unit weight before the construction work proceeds.

Excavation for structures shall be extended sufficiently beyond the limits of the structure to provide ample room for form construction and other construction methods to be followed, wherever necessary.

B. Bedding

Where the subgrade below the bottom of the pipe is disturbed during the construction, the space shall be refilled with sand or pea gravel bedding material solidly tamped to form a firm foundation for the pipe. Sand or pea gravel bedding material shall be extended to one (1) foot above the pipe, except that the bedding shall be exclusively pea gravel to the springline for pipe 36-inch and greater in diameter.

C. Amount of Trench Opening

Not more than 50 feet of trench shall be open at one time in advance of the pipe unless permitted by the ENGINEER. The length of street that may be occupied by the construction work at any one time shall be subject to the direction of the ENGINEER and will be based on requirements of the use of the street by the public. No more than 600 consecutive feet of street length shall be occupied at one time, and vehicle traffic through the street shall not be entirely stopped without permission of the ENGINEER.

After placement of the utility line, the Contractor shall backfill the trench promptly in order to minimize the length of open trench and avoid any unsafe conditions.

15. TRANSPORT OF NATIVE MATERIALS OFFSITE

If the Contractor encounters good materials (sand, gravel, topsoil, etc.) during the course of construction, he shall not be allowed to transport these materials offsite without the written approval of the Engineer. Wherever possible, suitable native sands and gravels shall be used as backfill rather than transporting them offsite and replacing them with non-native materials of a lesser quality.

16. STONE REFILL FOR TRENCH UNDERCUT

In locations where soil at the bottom of trench is unstable, the CONTRACTOR shall excavate (undercut) below the trench bottom and place stone refill as called for in the Materials Section of this specification.

17. EXCAVATION & TRENCH DEWATERING

The CONTRACTOR shall maintain any excavation or trench free of water during construction of any structures and/or pipelines. Water accumulated due to rainfall or runoff and minor groundwater inflow that

can be controlled through the use of portable trash, submersible or positive displacement pumps shall be considered normally expected and anticipated conditions associated with underground construction. This effort will be considered incidental to the cost of construction and will not be reimbursable at the unit price bid for dewatering in the proposal.

The required use of deep wells and/or well points to lower and maintain a reduction in the groundwater elevation below the trench bottom shall be subject to approval of the ENGINEER and shall constitute a reimbursable expense for trench or excavation dewatering. If a pay item for dewatering is included in the Bid Form, then the CONTRACTOR would receive payment for this work based upon the unit bid price. If there are no provisions in the contract for payment for dewatering (i.e. bid item or incidental to other pay items), then the CONTRACTOR shall submit a detailed estimate of the additional cost. Upon acceptance of the CONTRACTOR's estimate, the ENGINEER shall issue a change order. The CONTRACTOR must demonstrate that a continuous effort is required to control hydrostatic pressure in the construction area in order to claim compensation for dewatering.

The CONTRACTOR shall take adequate precautions to control the discharge of dewatering pumps so as to prevent soil erosion or sedimentation of drainage ditches, structures, storm sewers, culverts, natural drainage courses, ponds, lakes or wetlands.

The CONTRACTOR shall insure that discharge from any dewatering operations has a suitable outlet and that it will not cause any damage to adjacent dwellings or property. Water and discharge hoses shall be placed and/or controlled so as to prevent a hazard to pedestrians or motor vehicles passing in the vicinity of the construction site.

Electric pumps shall have suitable power supply appurtenances meeting NEC requirements and properly fused and grounded to prevent electrical shock hazards to on-site personnel.

Internal combustion engine driven pumps, if operated 24 hours per day, shall have adequate exhaust silencers in good repair to muffle engine noise to an acceptable level for the area where located.

18. DIVERTING EXISTING SEWERS

Where existing sewers or drains are encountered in the Work, adequate provision shall be made for diverting flow in the existing sewers so that the excavation will be kept dry during the progress of the construction work. Upon completion of the construction work, the existing sewers shall be restored or otherwise provided with an adequate outlet as directed by the ENGINEER.

19. SHEETING, BRACING & SHORING

Where required to properly support the surfaces of excavations to protect the construction work, adjacent work or workers, sheeting, bracing and shoring shall be provided. If the ENGINEER is of the opinion that at any point sufficient or proper supports have not been provided, he may order such additional supports at the expense of the CONTRACTOR, but neither the placing of such additional supports by the order of the ENGINEER nor failure of the ENGINEER to order such additional supports placed shall release the CONTRACTOR from his responsibility for the sufficiency of such supports and the integrity of the Work. In removing the sheeting and bracing after the construction has been completed, special care shall be taken to prevent any caving of the sides of the excavation and injury to the completed work or to the adjacent property.

20. SHEETING LEFT IN PLACE

Sheeting, bracing and shoring shall not be left in place after completion of the work except as required by the ENGINEER. Where sheeting, bracing, and shoring must be left in place in order to protect the work, adjacent structures, or property, it shall be cut off or left not less than two (2) feet below the established surface grade. If sheeting, shoring or bracing must be left in place, then it shall be paid for at the contract unit bid price that is shown on the Bid Form. If a pay item was not included on the Bid Form, then a work order shall be negotiated.

21. CROSSING EXISTING STRUCTURES/PIPES

During construction, it may be necessary to cross under certain sewers, drains, culverts, water lines, gas lines, electric conduits and other underground structures. Every effort shall be made to prevent damage to such structures. Wherever such structures are disturbed or broken, they shall be restored to good condition. Specified granular backfill shall be placed as described in Section 23, Backfilling. MDOT Grade S3 concrete shall be utilized where directed by the ENGINEER at no additional cost to the project. Either granular backfill or concrete shall be brought to the spring line of the higher utility.

22. TUNNELING TREES

Trees eight (8) inches in diameter or less will require a minimum tunnel length of eight (8) feet. Trees over eight (8) inches in diameter, measured four (4) feet above the ground surface, will require a minimum tunnel length equal to one foot for each inch of tree diameter.

Trees shall be tunneled whenever any portion of an excavation approaches within a distance equal to one-half the required tunnel length except as otherwise noted on the plans.

Tunneling under trees may be accomplished by one of the following methods:

- a. Boring and jacking casing pipe along with placement of a carrier pipe.
- b. Boring and jacking sewer pipe or water main without a casing pipe.
- c. Jacking sewer pipe or water main without boring and without a casing pipe.

Plan notes or existing field conditions shall indicate which method may be used for the tree tunneling work.

23. BACKFILLING

A. General

Backfilling shall include all work required as hereinafter specified. The placement of various pipe, including bedding and building of structures, shall be completed prior to backfilling.

Where called for on the plans, the CONTRACTOR shall backfill trenches and/or other excavations with suitable excavated material (not including gray or blue clay) replaced into the trench or excavation and compacted to not less than 95 percent of maximum unit weight as determined at existing moisture content during backfilling. Compaction shall be provided by means of suitable mechanical compaction equipment.

If the moisture content of cohesive backfill material exceeds the optimum moisture content for maximum density by more than three percent (3%), the CONTRACTOR shall dry the material to meet the foregoing moisture content limitation or provide, at his own expense, MDOT Granular Material Class III. No sloppy or wet backfill will be allowed.

Maximum unit weight will be determined by current methods of Test for Compaction and Density of Soil, AASHTO Designation T-180 or by the Cone Density Method

developed by MDOT, as the material may require.

The ENGINEER shall make compaction tests at all locations requiring granular backfill.

Any depression resulting from settlement of any backfill prior to the date of final payment for all work under this contract shall be brought to the proper grade and surface and made to match the adjacent surface.

B. Materials

Bedding, excavated backfill, and granular backfill shall conform to the requirements that were previously described in Parts 3 and 4 of this specification.

C. Compaction

Backfill material shall be placed in layers not to exceed 12 inches in thickness unless the contractor can demonstrate to the satisfaction of the Engineer that he can consistently attain the specified density on thicker lifts.

Specified compaction shall be obtained with the use of a bulldozer, sheepsfoot roller, mechanical tamper or other similar and effective equipment. Specified compaction means not less than 95 percent (not average 95 percent) of maximum unit weight when tested in accordance with current MDOT Specifications.

If excavated material is not suitable to obtain 95 percent minimum compaction, the CONTRACTOR shall, at his expense, remove unsuitable materials or add granular materials, or both, to obtain ninety-five percent (95%) minimum compaction as specified.

Compaction tests will be made by a representative of the OWNER and paid for by the OWNER, unless otherwise specified in the Contract Documents.

D. Backfilling Trenches

Bedding

The type of bedding required is shown on the detail drawings.

Bedding shall be worked under the haunches of the pipe to provide firm continuous support.

Bedding placed on the sides of and above the pipe shall be compacted by machine tamping to not less than ninety-five percent (95%) of maximum unit weight in layers not exceeding 12 inches in depth.

Trench or Excavated Area

All trenches in paved streets, shoulders, traveled roadways, parking areas and driveways shall be backfilled with suitable excavated backfill or granular backfill, as shown on the drawings from one (1) foot above top of pipe up to the required subgrade elevation which will allow for placement of the required gravel base and/or pavement surface. The approved excavated backfill or granular backfill shall be placed and thoroughly and uniformly compacted by machine tamping to the specified compaction. With the approval of the ENGINEER, water jetting may be accepted in lieu of tamping for granular backfill only.

Specified compaction shall be required of the entire trench when the edge of trench is within three (3) feet of edge of pavement. On road crossings, specified compaction shall extend ten (10) feet beyond the edge of pavement for paved roadways with gravel shoulders or shall extend three (3) feet beyond the back of curb for roadways with curb.

Trenches under concrete sidewalks and bike paths shall be backfilled from one foot above top of pipe to a level four (4) inches below finished grade of the sidewalk with approved suitable excavated backfill or

granular backfill and compacted to ninety-five percent (95%) maximum density.

Trenches not in paved streets, shoulders, traveled roadways, parking areas, driveways or under sidewalks, shall be backfilled from one (1) foot above the top of the pipe up to the ground surface (except as noted under the Restoration Specification) with suitable excavated backfill and shall require compaction equal to adjacent undisturbed earth.

Wherever gas mains, water mains, sewers, or other utilities are located in the trench area, granular backfill shall be used for backfill from bottom of the trench up to the springline of the pipes. Granular backfill shall be placed across the full trench width and extend far enough either side of the existing pipe to allow specified compaction so as to thoroughly support the pipe within the trench area.

E. Backfilling Around Structures

As soon as practicable after concrete structures have set, forms and debris shall be removed and the surface of the concrete pointed. After the structure has been checked and approved, the excavated area around the structure shall be backfilled up to specified subgrade with granular material or suitable excavated material as called for on the drawings for the adjacent trench. The fill shall be thoroughly compacted by machine tamping. No large boulders or masonry shall be placed in backfill. No backfill will be placed against manhole walls within 48 hours after the plaster coat has been applied to the outside of the walls nor shall backfill be placed about concrete structures until concrete has attained at least 75 percent of its design strength and approval of the ENGINEER has been obtained.

24. PLACING AND COMPACTING EMBANKMENT

Embankment material for fill work shall be placed and compacted in accordance with

Section 2.05.03H of the MDOT Standard Specification for Construction.

25. DISPOSAL OF EXCAVATED MATERIAL

After all suitable excavated material has been used on site, the CONTRACTOR shall be responsible for properly removing and disposing of the excess.

The CONTRACTOR shall also be responsible for disposing of all other excavated materials that are unsuitable for use as fill or backfill. Unsuitable materials may include, but are not limited to, broken concrete, asphalt, rock, stone, and other related debris. The CONTRACTOR shall be required to obtain his own disposal areas and permits and shall receive no additional compensation for this disposal work.

Surplus or unsuitable material shall not be disposed of either temporarily or permanently beyond the plan grading limit line or across any wetland or flood plain unless the plans provide for such placement.

Any agreements that the CONTRACTOR makes with local residents concerning the placement of fill on private property shall be the sole responsibility of the CONTRACTOR. The OWNER will not become involved with any such agreements and will not be liable for damages that the CONTRACTOR may cause to private property.

Placement of fill on private property may require that the resident or CONTRACTOR obtain a grading permit or fill permit from the OWNER.

26. FINAL CLEANUP & GRADING

Upon completion of the construction, and before final payment is made, the CONTRACTOR shall restore his working area to as clean a condition as existed before his operations were started. He shall go over the entire line and refill any place that may

have settled. He shall then re-grade and put in shape all backfilled trenches, all fills he may have made from excess excavated materials, and all other areas that may have been disturbed through all operations.

27. CONTRACTOR SAFETY REQUIREMENTS

The excavation and trenching operations shall be conducted by the CONTRACTOR in a manner that will provide safe working conditions for all persons on the site who may be affected by the Work. The CONTRACTOR shall also conduct his operations in a manner that will protect adjacent property from damage.

Trench sides shall be either cut back to the slope as necessitated by soil and ground water conditions which will provide stable sides, or supporting systems shall be installed that are capable of restraining the earth sides from movement. A qualified employee of the CONTRACTOR shall design the trench supporting systems.

The CONTRACTOR shall employ, at all times at the site of the work, a qualified person who will be responsible for the safety of both the work and workmen, and who will make all the decisions relevant to the stability of trenches, the adequacy of any and all protective devices, proper operation of equipment, and all other matters related to safety.

The CONTRACTOR shall not store, along and adjacent to the trench, excavated material, heavy equipment, backfill materials, sewer pipe, or other construction materials which may impose too great a load on the earth and cause displacement or caving of the earth. The CONTRACTOR shall, at all times, provide a safe means of emergency exit from all trench excavations.

End of Section

METHOD OF PAYMENT

GENERAL

A. PRICES AND MEASUREMENT:

Payment for work under this contract will be based on a unit price or lump sum for work actually completed. Final measurements of the work will be taken by the Engineer to determine the amount of work done and thereby determine the total cost. The method of applying the unit prices to measured quantities will be as herein specified. Payment will include the cost of all labor, tools, materials, and equipment necessary to do the work.

Several items may have been included in the bid form but may not be called for on the plans. These items have been included in order to establish a unit price in the event that the item of work is necessary. The Contractor should be aware that these items may increase, decrease, or be zero based on field conditions, or Owner direction.

For more information on unit prices/bid items, see Michigan Department of Transportation 2020 Standard Specifications for Construction and Appendix A for Special Provisions.

B. INCIDENTAL ITEMS:

Any items of work indicated as incidental or included shall be considered as part of the project work and shall be completed at no additional expense to the Owner. Incidental or included items shall include labor, materials, and equipment that may not be specifically listed in the Bid Form or in the drawings or specifications, but which are necessary to complete the work.

C. PERMITS:

Applicable permits have been applied for by the Owner of this project. The permits must be acquired from the appropriate agency by the Contractor when they are approved. Any permit fees, bonds, and/or permit agency inspection costs will be the responsibility of the Contractor and shall not result in additional cost to the Owner. A list of permits required for this project is shown in the Supplemental Instructions to Bidders section.

SUPPLEMENTAL SPECIFICATIONS

1. General.....	2
2. Location of Project.....	2
3. Scope of Project.....	2
4. Construction Standards.....	2
5. Progress Meetings.....	2
6. Easements & Easement Conditions.....	2
7. Incidental Contract Items.....	2
8. Project Coordination With Owner & Other Contractors.....	2
9. Incentive/Disincentive Provisions.....	3
10. Federal Requirements.....	4
11. Fair Employment Practices Act.....	4
12. Observation of Construction.....	4
13. Hours of Work.....	4
14. Testing & Sampling.....	4
15. Staking.....	5
16. Station Grading.....	5
17. Traffic Maintenance & Control.....	5
18. Load Restrictions on Local Streets.....	7
19. Utilities.....	7
20. Emergency Repair.....	7
21. Use of Water.....	9
22. Asphalt and Pavement Construction.....	9

1. GENERAL

These Supplemental Specifications are supplements to the General Conditions and General Specifications. Where conflicts exist between the aforementioned Contract Documents, the conditions in the Supplemental Specifications shall govern.

2. LOCATION OF PROJECT

The project site at the Northfield Township Hall at 8350 Main St.

3. SCOPE OF PROJECT

The work to be done under this Contract includes the furnishing of all materials, equipment, and labor necessary to construct the proposed parking lot, sidewalks, curb and gutter, storm system, restoration and pavement markings as well as all necessary earthwork, cleaning and restoration in accordance with the plans and specifications.

4. CONSTRUCTION STANDARDS

It is the intention of these specifications to construct all work in accordance with applicable requirements of the Township of Northfield, the Washtenaw County Road Commission, and the Washtenaw County Drain Commission these specifications, and the plans referenced herein. Where there is a conflict between any of the aforementioned specifications and the permit requirements of the agency controlling the respective utility or rights-of-way, the more restrictive shall govern.

5. PROGRESS MEETINGS

During the life of the project biweekly progress meetings may be held to discuss the project status, potential construction problems, the schedule, and other items that may impact the progress of the work. This meeting shall be attended by the CONTRACTOR, any subcontractors whose work is in progress or will be started in the two weeks following the progress meeting, the ENGINEER and the OWNER. The date, place, and time of the first progress meeting will be set at the preconstruction meeting and subsequent meetings will follow every two (2) weeks.

6. EASEMENTS & EASEMENT CONDITIONS

There are no easements associated with this project.

7. INCIDENTAL CONTRACT ITEMS

All items of work noted on the plans or in the specifications that are not specifically noted in the Bid Form as a pay item shall be considered included in the pay items provided for the construction of the project and shall be constructed at no extra cost to the OWNER.

8. PROJECT COORDINATION WITH OWNER & OTHER CONTRACTORS

The OWNER, utility companies, and commercial or private owners may have construction projects occurring within or adjacent to the project limits during the life of this Contract.

The CONTRACTOR shall coordinate his construction with all such projects that may be ongoing in the vicinity.

Also, where the CONTRACTOR's work affects the operation of the OWNER's utilities, the CONTRACTOR shall be responsible for coordinating his work with the OWNER. The CONTRACTOR shall give at least 72 Hours hours notice to the OWNER in order to schedule activities such as valve operation, hydrant operation, sewer and structure cleanout, etc. No claim for extra compensation or adjustments in Contract Unit Prices will be allowed on account of delay or failure of others to complete work scheduled.

9. INCENTIVE/DISINCENTIVE PROVISIONS

This project is on an expedited schedule. The CONTRACTOR will be expected to mobilize sufficient manpower and equipment and to work the required overtime to maintain the expedited schedule. In addition, the CONTRACTOR shall take into account all seasonal and weather limitations described in the Contract Documents when preparing the progress schedule. The CONTRACTOR is responsible for all means to protect the work from the weather, and shall include these costs in the bid items for the work. This project will be completed in accordance with the Time of Completion and Construction Schedule section of the Supplemental Specifications.

Completion Dates

Disincentive – If the CONTRACTOR fails to complete all work as described above before the date of 10/15/2024, the CONTRACTOR will be charged for each calendar day that the project is not completed. These charges will be assessed for every calendar day, including calendar days throughout the winter, until the work is completed. The disincentive charges will be as set forth below.

Disincentive will be paid or assessed as follows:

Disincentive – For each day beyond 10/15/2024 during which the sidewalk, path, and ADA crossing remains incomplete, payments owed to the CONTRACTOR shall be decreased by \$800 per calendar day. In addition, the CONTRACTOR will be assessed liquidated damages per day.

The entire project shall be completed on or before 10/15/2024. Liquidated damages will be assessed for failure to complete on time in accordance with the Supplemental Specifications. Damages will continue to be assessed until the project is completed.

No extension of time will be granted for labor disputes unless it can be shown that such disputes are industry wide.

Any extra costs incurred by the CONTRACTOR due to cold weather protection, night work, winter grading, insufficient manpower, and equipment necessary to maintain the expedited schedule and/or meet the completion date, and any overtime utilized will not be paid for separately.

No extension of time will be granted for delays in delivery of critical material unless the delay can be shown to be industry-wide and the delay affects a critical item of work.

10. FEDERAL REQUIREMENTS

A. None

11. FAIR EMPLOYMENT PRACTICES ACT

The CONTRACTOR agrees that neither he nor his subcontractors will discriminate against any employee or applicant for employment. The CONTRACTOR shall not discriminate with respect to his hire, tenure, terms, conditions or privileges of employment, or any matter directly or indirectly related to employment, because of race, color, religion, national origin or ancestry, nor shall age or sex be a condition of employment except where based upon an occupational qualification. Breach of these covenants may be regarded as a material breach of this Contract.

12. OBSERVATION OF CONSTRUCTION

All construction operations will require full time observation by the OWNER's representative. The CONTRACTOR must notify the ENGINEER at least three (3) working days (72 hours) prior to construction and no work shall be performed without the ENGINEER's presence or awareness. Contact the Construction Staffing Coordinator at (734) 522-6711 to schedule observation.

13. HOURS OF WORK

Work may be performed during the hours of 7:00 a.m. to 7:00 p.m., Monday through Saturday only. Work at other times may be performed only by written permission of the OWNER.

14. TESTING & SAMPLING

The CONTRACTOR shall furnish all samples of materials necessary for tests as determined by the ENGINEER or the Construction Observer. All samples taken for analysis and tests shall be taken in such a manner as to be truly representative of the entire lot under test. The CONTRACTOR shall furnish such assistance and facilities as the ENGINEER may require for collecting, storing or curing samples. Where materials tests are to be performed by the manufacturer, the certificates of approval shall be submitted to the ENGINEER. The cost of all such testing by manufacturers shall be incidental to the project. Additional required tests on materials in place shall be made at the expense of the OWNER, unless otherwise stipulated.

The OWNER's Agent shall arrange for and furnish testing services as provided by an acceptable independent laboratory as part of this Contract. These services shall be as follows, in addition to the testing requirements noted in the General Conditions:

All concrete shall be slump and air tested, with cylinders taken (as noted above) in compliance with the current MDOT Standard Specifications for Construction.

There may be areas with uncompacted fill material or organic materials; as a result, all areas within the influence of proposed pavement shall be proof rolled as a minimum, to the satisfaction of the ENGINEER. Some testing may be required.

All aggregate base and pavement shall be tested for compaction. A reputable firm, approved by the ENGINEER shall extensively test all such areas with a nuclear densimeter. In addition, all utility crossings and the areas immediately adjacent to any structures in the pavement shall be specifically tested. Areas which fail shall be compacted further and retested. Failure to pass a second test shall be reason to undercut and refill the area, as directed by the ENGINEER, with careful attention to compaction.

15. STAKING

The ENGINEER will provide construction staking. The staking shall consist of horizontal and/or vertical control staking for path construction at 50 foot intervals. The CONTRACTOR is responsible for providing a written request for staking to the ENGINEER at least seventy-two (72) hours in advance of starting work. Staking requests should be faxed to the attention of the OHM Survey Department at (734) 522-6427. The CONTRACTOR shall carefully preserve all stakes set by the ENGINEER. In the case of willful or careless destruction, the ENGINEER shall provide the restaking and the CONTRACTOR shall be charged with the resulting expense and shall be responsible for delays and errors caused by unnecessary loss or disturbance of the stakes. The expense for restaking will be entered as a deduct on pay estimates and the resulting amount retained by the OWNER for payment of restaking.

16. STATION GRADING

See Station Grading special provision.

17. TRAFFIC MAINTENANCE & CONTROL

A. General

During the course of construction, provisions must be made to maintain access for emergency vehicles at all times. Where possible and when directed by the ENGINEER, all streets must be left open to traffic at the end of each working day. Traffic maintenance and control as defined in this section shall be considered as included in the unit bid prices or lump sum bid prices that are given in the Bid Form.

All work for maintaining traffic and control shall be in accordance with Section 812 of the 2020 MDOT Standard Specifications for Construction and the current edition of the Michigan Manual of Uniform Traffic Control Devices, (MMUTCD). The Contractor shall also comply with work zone sign requirements as described in Public Act 315 of 2013.

The CONTRACTOR shall conduct his operations and use of equipment in such a manner that traffic will be maintained throughout the entire length of the project. When conditions are such as to warrant variations from this requirement, the procedure to be followed shall be approved by the ENGINEER prior to such procedure being put into effect.

The CONTRACTOR shall furnish, erect and maintain all barricades, signs and lights as required according to the current edition of the MMUTCD. Flagmen shall also be provided by the CONTRACTOR as necessary to protect the vehicular and pedestrian traffic and the work within the work zone areas. CONTRACTOR shall be responsible for notifying concerned parties such as Police, Fire, and school officials if a road closure and/or detour will be in effect. The CONTRACTOR shall notify the same parties when the road has been reopened.

Once work on a particular utility is begun, the CONTRACTOR must continue his work to completion. The OWNER will not permit random movements of work operations among the project area that tend to confuse traffic patterns.

B. Provision for Local Traffic

During the progress of the work, the CONTRACTOR shall accommodate both local vehicular and pedestrian traffic along the roads.

Access to all residences and businesses shall be maintained except as noted on the plans or as directed by the ENGINEER.

The CONTRACTOR's truck and equipment operations on public streets shall be governed by all local traffic ordinances and regulations of the Fire and Police Departments, the OWNER, and Michigan Department of Transportation.

C. Existing Warning and Regulatory Signs

Wherever possible, all existing signs on this project are to be preserved and maintained as incidental to the project.

Where it is not possible to preserve existing traffic control signs and street name signs, they shall be removed, temporarily reset and maintained by the CONTRACTOR. Upon completion of the project, the CONTRACTOR will reset traffic control signs and street name signs in the proper position.

In cases where new signs are called for, they shall be placed in accordance with the requirements outlined elsewhere in the Contract Documents.

Any new or existing signs damaged by the CONTRACTOR shall be replaced in kind by him at no additional cost to the OWNER.

D. Lane Closures and Detours

Any lane closures or detours shall be approved by the OWNER and the appropriate governing agency, and shall meet their specifications and standards as well as those of the MUTCD. Where there are conflicts, the more restrictive requirement shall apply. If any type of closure is to occur during twilight or darkness, proper lighting will be required.

E. Construction Signs and Barricades

Warning signs and barricade configurations shall meet the requirements of the MUTCD, the OWNER, WCRC, and the Michigan Department of Transportation.

The CONTRACTOR shall not begin any operation on the project until all required signs and barricades have been set.

All signs to be used during twilight or darkness shall be reflectorized, in good condition, with two continuous flashing lights.

The construction site shall at all times be maintained and left in a clean, neat, and safe condition, including any construction signing.

After working hours, signs that are not appropriate shall be covered and/or removed so that motorists will not be confused. The CONTRACTOR shall also remove and replace or cover (where practical) existing traffic signs that may conflict with the proposed construction.

18. LOAD RESTRICTIONS ON LOCAL STREETS

The CONTRACTOR shall not operate heavy trucks or equipment on any side street within the project area without permission from ENGINEER, the OWNER or appropriate governing agency.

19. UTILITIES

The location of public or private utilities shown on the plans is in accordance with mapping provided by the utility owners. No guarantee is given that the locations are absolutely accurate or that utilities other than those shown are not present.

For protection of underground utilities, the CONTRACTOR shall contact "Miss Dig" at 1-800-482-7171 a minimum of three (3) working days prior to excavating. This does not relieve the CONTRACTOR of the responsibility of notifying utility owners who may not be part of the "Miss Dig" alert system.

During the course of the construction, the CONTRACTOR will encounter both overhead and underground utilities. The names and phone numbers of the utility company representatives are shown as follows:

Utility relocation work IS NOT expected to be necessary for this project.

The electric, gas and telephone public utilities have been notified of existing underground utilities and utility poles that are within the construction limits. Those utilities in conflict with the proposed construction will be relocated by the utility OWNER. The CONTRACTOR shall cooperate with utility company forces to minimize project delays.

In the event that utilities are encountered which require relocation, it shall be the CONTRACTOR's responsibility to arrange for and schedule the relocation of the affected utilities with the owners.

Work stoppages by employees of utility companies or any occurrence which results in a delay in utility relocations on this project may be considered as a basis for a claim for an extension of the time of completion, but will not be considered as a basis for a claim for extra compensation or an adjustment in Contract Unit Prices. The amount of any such time extension will be based upon the amount of delay actually experienced as a result of the utility relocation delay.

20. EMERGENCY REPAIR

When the CONTRACTOR is not actively performing work on a particular construction site, situations of an emergency nature may arise as a result of uncompleted work. Such situations may affect, directly or indirectly, public and/or private property, and may ultimately affect the health, safety, and welfare of individuals or the general public. The intent of this article is to provide a procedure to eliminate these problems as they occur. While these problem situations can and do readily develop as emergencies, the ENGINEER shall direct field-

related operations and require immediate efforts by the CONTRACTOR to remedy the deficiency in a method of his choosing because of his expertise in the field, time being of the essence. The correction of the “emergency” which may arise when no activity exists on the construction site shall be handled in the following manner:

- A. The ENGINEER shall observe the site, take any necessary photographs and/or prepare any necessary sketches of conditions at the site to determine that the situation constitutes an emergency.
- B. The ENGINEER then has three alternative sources of manpower and equipment to be selected to remedy the emergency situation in the following order:
 1. The CONTRACTOR under Contract with the OWNER to perform all work on the site location in question;
 2. The OWNER’s Water & Sewer
 3. An independent CONTRACTOR designated by the OWNER.

Since the nature and extent of most unfinished work on a particular construction site is well known by both the ENGINEER’s authorized agent and the CONTRACTOR at the time of declaring such an “emergency situation” as set forth herein before; the CONTRACTOR under Contract to the OWNER for the particular project would be the first party notified and would be expected to respond immediately with necessary manpower and equipment to remedy the problem.

If a reasonable time to respond to the emergency notification is not evident, in the best judgment of the ENGINEER, then the CONTRACTOR shall be judged to have waived his rights to physically correct the problem, but not his obligations to pay for such a physical correction or damages resulting there from. The ENGINEER shall then contact the OWNER’s Water & Sewer for their assistance in correcting the “emergency situation”. Where existing commitments by the Water & Sewer prohibit their immediate response to the request by the ENGINEER, the ENGINEER shall finally direct that corrective measures be performed by the independent contractor previously contacted by the OWNER to perform such emergency work when so directed.

Since the cost for all remedial work undertaken by the CONTRACTOR on this project shall be borne by the CONTRACTOR and it is necessary to engage the services of the Water & Sewer or an independent contractor, then all costs incurred would be deducted from monies due and payable to the CONTRACTOR on the particular project as set forth on any ensuing regular job estimates.

Typical costs which will be deducted from Contract monies due would be:

- A. Payroll wages
- B. Material bills
- C. Equipment rental (Detroit area rates) and moving costs
- D. 15% profit and overhead for independent contractor

E. 10% administrative costs

F. Observation costs

21. USE OF WATER

There is no access to public water.

22. ASPHALT AND PAVEMENT CONSTRUCTION

Asphalt and concrete pavements shall be constructed in accordance with the 2020 MDOT Standard Specifications for Construction unless otherwise indicated in the Supplemental Specifications, Appendix, plan notes, or plan details.

The cost of project related phone calls, including long distance charges are included.

Appendix A:
Special Provisions

NORTHFIELD TOWNSHIP

SPECIAL PROVISION
FOR
MAINTAINING TRAFFIC

OHM:TJL

1 of 2

2/23/2024

a. Description. Traffic shall be maintained by the Contractor throughout the project in accordance to Sections 104.11 and 812 of the 2020 Standard Specifications for Construction, the 2011 Michigan Manual of Uniform Traffic Control Devices, and any supplemental specifications in this proposal.

The Contractor shall notify the Engineer and City of Milan a minimum of 72 business hours prior to the implementation of any detours, road closures, or lane closures or major traffic shifts.

The Contractor shall coordinate his operations with Contractors performing work on other projects within or adjacent to the Construction Influence Area (CIA) or adjoining areas to avoid conflicts in the maintenance of traffic, construction signing, and to provide for the orderly progress of contract work.

b. Materials.

Traffic Control Devices. All traffic control devices and their usage shall conform to the Michigan Manual of Uniform Traffic Control Devices (MMUTCD), 2011 edition as revised, and as specified herein.

The Contractor shall place W21-4 signs (ROAD WORK AHEAD) on all cross roads within the project limits during construction as detailed on the construction signing plans.

Temporary warning, regulatory and guide signs not required for a particular work operation, shall be removed, completely covered, or laid down with the legs off, as directed by the Engineer.

Payment for all equipment, labor, materials and traffic control materials required to cover temporary signs shall be considered to be included in the cost of the temporary sign.

When signs for this project are to be covered, they shall be covered in accordance with Section 812.03 of the 2020 Standard Specifications for Construction and applicable details therein except as noted above.

Temporary signs that are to remain in place for 30 days or more shall be installed on permanent post mounts as directed by the Engineer. All other signs may be installed on portable supports.

All traffic control devices moved to facilitate to Contractors operation shall be replaced at the end of the workday. The Contractor shall routinely maintain the traffic control devices including, but not limited to proper placement, weighted with sandbags, replacement of lights and replacing damaged devices. The Contractor shall be

responsible for protecting the work area and shall supply the necessary traffic control devices apart from those called for on the plans to delineate the work area from adjacent property. The location for storage of materials and equipment shall be as approved by the Engineer.

1. All diamond-shaped warning signs shall be 48 inch x 48 inch mounted at a 7 foot minimum bottom height unless otherwise specified in the typicals.
2. Traffic Control shall be in accordance with the following MDOT typicals:

Tables for 'L', 'D' and 'B' Values (101-GEN-SPACING-CHARTS)

Ground Driven Sign Supports for Temporary Signs (WZD100-A)

Temporary traffic Control Devies (WZD-125-E)

NORTHFIELD TOWNSHIP
SPECIAL PROVISION
FOR
REIMBURSED PERMIT FEES

OHM: TJJ

1 of 1

2/15/2024

a. Description. The following permits are required to be obtained by the contractor as described in section 107 of MDOT 2020 Standard Specification for Construction. The contractor shall fulfill all obligations and post fees as part of the approved application.

Washtenaw County Water Resources Commissioner (WCWRC):

- Soil Erosion Permit.
 - This permit covers soil erosion within the project limits.
- Fees To be determined

Washtenaw County Water Road Commission (WCWRC):

- Right of Way Permit.
 - This permit covers work in the road right of way.
- Fees To be determined

b. Measurement and Payment. The completed work for **Permit Fees** will be paid for at the contract unit price for the following:

Pay Item	Pay Unit
Reimbursed Permit Fees	Dollar

Reimbursed Permit Fees will be reimbursed by the actual cost of the permit, (without any mark-up) incurred by the Contractor or Subcontractor(s), once submittal of original paid receipts from each permitting agency is provided to the Engineer that the permit fee has been paid. Permit Fees includes Contractor costs for agency off-site third-party permit and inspection fees. The Contractor will not be paid for permitting agency fines or fees resulting from but not limited to: unsatisfactory work, multiple inspections of unsatisfactory work, unsatisfactory work site and staging areas, unsatisfactory noise or dust control. Other required fees including, but not limited to insurance and bonds, shall be incidental to the Mobilization.

NORTHFIELD TOWNSHIP

SPECIAL PROVISION
FOR
PAVT REM, MODIFIED

OHM:TJL

1 OF 1

2/15/2024

a. Description. The existing pavement(s) shall be removed as shown on the plans and as specified in Section 204, Removing Miscellaneous Structures and Materials, of the Michigan Department of Transportation (MDOT) Standard Specifications for Construction except as modified herein.

b. Materials. None Specified

c. Construction Methods. All existing roadway and driveway pavement(s) to be removed shall be paid for once as "Pavt Rem, Modified", regardless of depth/thickness of pavement material being removed. The existing pavement may contain different materials with different depths of each material and potentially remnants of street railway system including ties, ballast, rails and spikes, plates and other material. The Contractor shall investigate the pavement cores/soil borings. No claims will be allowed for pavement thicker than anticipated, where no pavement core/soil boring data exists. "Pavt Rem, Modified" shall include excavation, removal and disposal of all pavements and materials necessary to construct the proposed improvements.

d. Measurement and Payment. The completed work for Pavt Rem, Modified will be paid for at the contract unit price for the following contract item (pay item):

Pay Item	Pay Unit
Pavt Rem, Modified	Square Yard

Pavt, Rem, Modified will be measured in its original position by the unit square yard and paid for at the contract unit price per square yard, which price shall be payment in full for all labor, materials, and equipment needed to accomplish this work.

NORTHFIELD TOWNSHIP

SPECIAL PROVISION
FOR
STATION GRADING

OHM: TJL

1 of 2

12/23/2023

a. Description: This work shall be done in accordance with Section 205 of the 2020 Michigan Department of Transportation Standard Specifications for Construction except as herein provided.

b. Construction Methods: The work of Station Grading shall consist of constructing earth grades by excavating soil or rock and placing embankments or fills as necessary to develop the cross sections shown on the details. The work shall include the salvaging and stockpiling of selected materials, disposing of surplus or unsuitable material, furnishing, and placing embankment materials, trimming the earth grade, and maintaining the work in a finished condition until acceptance.

Grading may be required to flatten or create slopes beyond edge of roadway. This excavation will be included in the payment for **Station Grading**.

All suitable excavated material from the project, including undercut and sewer trench excavation, can be used to construct embankments (fill), backfill muckholes, or flatten slopes as directed by the Engineer.

All surplus excavated and unsuitable or waste material not able to be incorporated into the project shall become the property of, and shall be disposed of by, the Contractor. The Contractor shall follow federal, state and local regulations in the disposal of surplus materials.

Station Grading shall include all required excavation and embankment within the grading limits as shown on the plans and as directed by the Engineer. In addition to the items as specified in the Standard Specifications for Construction, the following items are included:

1. Removing trees and vegetation smaller than 6" in diameter.
2. Root cutting where necessary to construct path. If enough roots of a tree need to be removed where the tree may die, the entire tree is to be removed.
3. Grading, topsoil stripping and removal, excavation, disposal of unsuitable aggregate base, subgrade material, and embankment for those roads that are to be reconstructed.
4. Backfilling existing ditches or ditching necessary to convey road drainage as indicated on the plan.
5. Removal of shrubs located within the public right-of-way.
6. Removing headwalls within the public right-of-way.

7. Removal of non-concrete or non-asphalt driveway materials. (i.e. gravel, etc.)

c. Measurement and Payment: The completed work as measured along the construction centerline shall include the entire grading limits on both sides of the road and will be paid for at the contract unit price for the following contract item (pay item):

<u>Pay Item</u>	<u>Pay Unit</u>
Station Grading	Square Yard

Earthwork and grading for HMA parking lots, curb and gutter repairs and sidewalk repairs shall be included in the cost of **Station Grading**. All payment for **Station Grading** shall be measured by the square yard.

NORTHFIELD TOWNSHIP
SPECIAL PROVISION
FOR
SUBGRADE UNDERCUT AND REFILL

OHM: TJL

1 of 1

2/15/2024

- a. Description.** This work shall consist of undercutting and backfilling to replace material that in the opinion of the Engineer is susceptible to frost heave or differential frost action and to remedy unstable soil conditions. This work shall be done in accordance with Section 205 of the 2020 Standard Specifications for Construction except as provided herein.
- b. Materials.** Backfill shall consist of MDOT 21AA limestone
- c. Construction.** If areas of poor soil are exposed and directed to be undercut by the Engineer, the undercut shall follow the requirements of the Michigan Department of Transportation 2020 Standard Specifications Section 205.
- d. Measurement and Payment.** The completed work as described will be measured and paid for at the contract unit price using the following contract items (pay items):

<u>Pay item</u>	<u>Pay Unit</u>
Subgrade Undercut and Refill, 21AA	Cubic Yard

Subgrade Undercut and Refill, 21AA shall be measured compacted in place and shall be based upon the average length, width, and depth measurements of the undercut areas as determined by the Engineer. Undercut areas that are not authorized or measured by the Engineer will not be considered for payment.

The contract unit price shall be payment in full for all labor, material, and equipment necessary to remove unsuitable subgrade material, in the opinion of the Engineer, and replace with MDOT 21AA limestone, as directed by the engineer, and compacted to at least 95% of their maximum unit weight. It shall include all costs for disposing of the excavated material offsite by the Contractor and all other costs associated with the work.

NORTHFIELD TOWNSHIP
SPECIAL PROVISION
FOR
UTILITY STRUCTURE ADJUST

OHM:TJL

1 of 2

2/23/2024

a. Description. This work shall consist of adjusting water, storm or sanitary sewer structures when the total amount of vertical change is six inches or less. This work shall be done in accordance with Section 403 of the MDOT 2020 Standard Specifications for Construction except as provided herein.

b. Materials. Furnish materials in accordance with subsection 403.02 of the Standard Specifications for Construction with the following exceptions:

Mortar for use in water, storm or sanitary structures shall conform to Section 702 of the MDOT 2012 Standard Specifications for Construction.

Furnish Concrete, Grade 4000 in accordance with section 1004 of the Standard Specifications for Construction. Furnish lane ties (if required) in accordance with sections 603 and 914 of the Standard Specifications for Construction.

For concrete, curb; concrete, curb and gutter; or concrete traffic island repairs furnish materials in accordance with the standard specifications.

c. Construction Methods. For structures within the pavement area, use a rotary coring head to remove a minimum 4-foot diameter section of pavement around the utility structure frame and cover. If the frame outside diameter measurement is greater than 36 inches, use a rotary coring head to remove a minimum 4.5-foot diameter section of pavement. A 2.5-foot diameter rotary core shall be used for water "D" boxes. Joints shall extend from structure out to corners of sawcut area.

Support the cover frame over the structure matching the adjacent roadway cross slope. Secure the frame in-place to allow for placement of concrete without altering frame position.

For structures within the pavement area, replace pavement around the frame with Concrete, Grade 4000 matching the finished elevation and cross-slope of the roadway. Construct plane of weakness joint as directed by the Engineer. For structures within the curb line, replace pavement around the frame with Concrete, Grade 4000 and HMA top course as shown in Figure 1. Install epoxy anchored lane ties to anchor the concrete to adjacent composite pavement for curb drainage structures located in curbed areas. Replace concrete, curb; concrete curb and gutter, or concrete traffic control islands "in-kind" in accordance with the Standard Plan R-30 Series and section 802 of the Standard Specifications for Construction.

Immediately remove any debris that falls into the structure due to Contractor operations.

Epoxy anchor all lane ties in accordance with section 603 of the Standard Specifications for Construction.

Ensure saw cuts, core cuts and any saw overcuts are cleaned and sealed with hot poured rubber asphalt.

d. Measurement and Payment. The completed work as measured for Utility Structure Adjust will be paid for at the contract unit price for the following contract item (pay item):

Pay Item	Pay Unit
Structure Cover, Adj, Case 1, Conc Collars.....	Each

The work of sanitary sewer, gate well and water box structures shall be paid for on a per structure basis and shall apply when the total amount of vertical change of the casting (up or down) is six inches or less. The pay item **Structure Cover, Adj, Case 1, Conc Collars** shall apply to all manholes or boxes. The adjust structure pay item shall not apply to new structures as final adjustment in this case is included in the contract unit price of the new structure.

Structure Cover, Adj, Case 1, Conc Collars includes witnessing of structures, saw cutting and removal of existing pavement and curb or curb and gutter, adjustment of cover to required elevation and cross-slope, installation of epoxy anchored lane ties (curbed areas only in composite sections), placement and finishing of new curb or curb and gutter, placement and finishing of new concrete, placement and removal of temporary HMA wedging for maintaining traffic, if required, placement of cover to open structures to prevent accumulation of debris and cleaning existing drainage structure due to Contractor operations.

NORTHFIELD TOWNSHIP

SPECIAL PROVISION
FOR
BUMPER BLOCKS

OHM:TJL

1 OF 1

2/23/2024

a. Description. The existing bumper blocks shall be removed, salvaged and reset as shown on the plans.

b. Materials. New precast concrete bumper blocks shall meet the size shown on the plans. Anchor pins shall be 3/8" x 18 steel anchor pins.

c. Construction Methods. All existing bumper blocks and anchor pins shall be removed, salvaged and reinstalled with new anchor pins at all existing locations.

d. Measurement and Payment. The completed work for **Rem and reset bumper blocks** will be paid for at the contract unit price for the following contract item (pay item):

Pay Item	Pay Unit
Rem and reset bumper blocks.....	Each

Rem and reset bumper blocks will be measured in its original position by the each and paid for at the contract unit price per each, which price shall be payment in full for all labor, materials, and equipment needed to accomplish this work. This item included the replacement of up to 5 damaged bumper blocks as directed by the engineer. The unit price for Rem and reset bumper blocks also includes the disposal of the damaged bumper blocks and used anchor pins.

NORTHFIELD TOWNSHIP

SPECIAL PROVISION
FOR
PAVEMENT MARKINGS

OHM:TJL

1 of 1

2/23/2024

a. Description. This work consists of applying pavement marking material to the parking lot parking spaces.

b. Materials. Pavement marking material shall be waterborne paint from the Qualified Products Lists, 811.03.

c. Construction. Apply pavement marking material uniformly at the rates shown in Table 811-1 of the Standard Specifications for Construction. For materials not shown on this chart, use the specifications shown in the separate special provision for the material to be used, or the manufacturer's recommendations. Ensure curb markings are retro-reflective and have no visible drips.

d. Measurement and Payment. The completed work, as described, will be measured and paid for at the contract unit price using the following pay item:

Pay Item	Pay Unit
Pavement Markings	Lump Sum

The **Pavement Markings** pay item includes all pavement markings either yellow or blue and the required handicap symbols in the dedicated parking spaces.

NORTHFIELD TOWNSHIP
SPECIAL PROVISION
FOR
STORM SEWER STRUCTURES

OHM: TJL

1 of 2

2/23/2024

- a. **Description.** This work shall consist of furnishing and rehabilitating existing storm sewer structures as part of sewer construction. This work shall be done in accordance with Section 203, 206, 402, 403 and ASTM D2321 of the MDOT 2020 Standard Specifications for Construction except as provided herein.
- b. **Materials.** The materials specified in the standard details Section 403 of the 2020 Michigan Department of Transportation Standard Specifications for Construction apply unless modified by this special provision or otherwise directed by the Engineer.
- c. **Construction Methods.** Construct in accordance to Section 403 of the 2020 MDOT Standard Specifications for Construction.
- d. **Measurement and Payment.** The completed work as described will be measured and paid for at the contract unit price using the following contract items (pay items):

Pay Item	Unit
Dr Str Flattop, Rem and Replace, 72 in	Each

Dr Str Flattop, Rem and Replace, 72 in, are to be measured and paid for by the each. The contract unit price shall be payment in full for all labor, materials, and equipment necessary to remove and replace the existing flattop for the drainage structure in accordance with plan details. Payment will include the following: excavating; trenching; disposal of unsuitable or excess excavated materials; temporary sheeting, bracing, and shoring of excavations; trench stabilization; supporting of existing pipe lines, building leads, and other utilities; furnishing and placing of flattop, jointing materials, frame, fittings, and other adaptors; furnishing and placing of all materials listed under this special provision for the construction of drainage structures; furnishing and placing of required bedding, backfill, and fill materials; cutting, and connecting existing storm sewer lines; and complete cleanup. Payment for **Dr Str Flattop, Rem and Replace, 72 in** also includes adjusting the casting to finish grade.

NORTHFIELD TOWNSHIP
 SPECIAL PROVISION
 FOR
SIDEWALK, CONC, THICKENED EDGE

OHM: SEB

1 OF 1

07/27/2022

a. Description. The work shall consist of placing and grading the concrete sidewalk as shown on the plans and as specified in Section 803 of the Michigan Department of Transportation (MDOT) 2020 Standard Specifications for Construction except as modified herein.

b. Materials. The material to be used for Sidewalk shall be 3500 or 3500HP. Sand meet requirements of Granular Material Class II, Section 902 of MDOT 2020 Standard Specifications for Construction

c. Construction Methods. Sidewalk pay items shall include furnishing, placement and compaction of the sand base to a minimum depth of 4 inches compacted in place, prior to concrete placement. Work includes excavating base material, transport and disposal of excess materials excavated, spoils removal, sand placement, compaction, sawing if required, proper placement of sidewalk material and expansion material as required. The sidewalk shall be 6 inches in thickness.

d. Measurement and Payment. The completed work for **Sidewalk, Conc, _ inch**, will be paid for at the contract unit price for the following contract item (pay item):

Pay Item	Pay Unit
Sidewalk, Conc, Thickened Edge	Sft

Sidewalk, Conc, Thickened Edge will be measured in its original position by the unit square foot and paid for at the contract unit price per square foot, which price shall be payment in full for all labor, materials, and equipment needed to accomplish this work. The exposed face shall have a hand rubbed finish and be constructed.

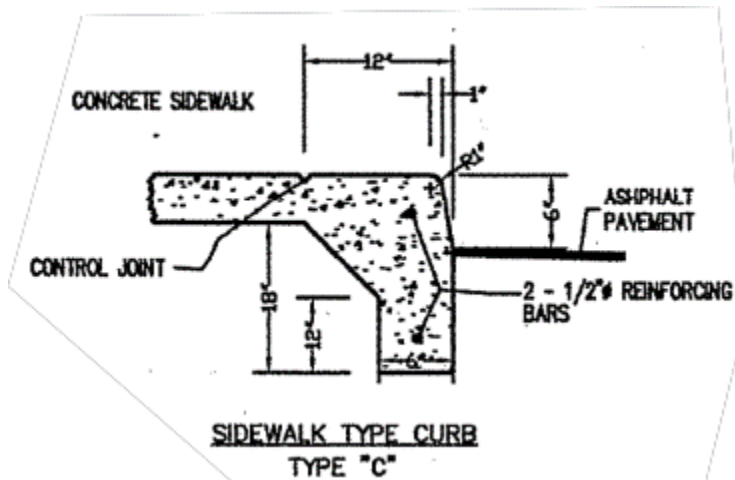

NORTHFIELD TOWNSHIP

SPECIAL PROVISION
FOR
TRAFFIC CONTROL

OHM:TJL

1 of 1

2/23/2024

a. Description. This work consists of providing, using and removing all traffic control needed to provide a safe project site for the contractors, township officials and public.

b. Materials. Channeling Devices and temporary signage shall meet the requirements of section 812 of the 2020 Standard Specification for Construction.

c. Construction. Use of traffic devices as stated in section 812 of 2020 Standard Specification for Construction.

d. Measurement and Payment. The completed work, as described, will be measured and paid for at the contract unit price using the following pay item:

Pay Item	Pay Unit
Traffic Control	Lump Sum

The **Traffic Control** pay item includes all channelizing devices (minimum of 50), Type B temp signage as required by WCRC for ROW work and pedestrian barricades as needed to provide safe access to buildings.

NORTHFIELD TOWNSHIP WASHTENAW COUNTY, MICHIGAN NORTHFIELD TOWNSHIP HALL

NORTHFIELD TOWNSHIP BOARD OF TRUSTEES

KENNETH DIGNAN III
• SUPERVISOR •

KATHY MANLEY
• CLERK •

JANET CHICK
NATHAN MUCHOW

TIM SAVILLE
RACHEL SMITH
• TRUSTEE •

JACQUELINE OTTO
• TREASURER •

INDEX OF SHEETS	
SHEET NO.	DESCRIPTION
1	COVER SHEET
2	GENERAL NOTES
3	LEGEND
4	REMOVAL AND CONSTRUCTION PLAN
5	SOIL EROSION AND SEDIMENTATION CONTROL
6	PAVEMENT MARKING PLAN
CE-1	DIMENSION & PAVING PLAN BY OTHER
CE-3	EROSION CONTROL PLAN BY OTHER
CE-10	STORM SEWER DETAILS BY OTHER

M.D.O.T. STANDARD PLANS	
TITLE	PLAN NO.
DRAINAGE STRUCTURES	R-1-G
COVER B	R-7-F
COVER E	R-10-D
COVER K	R-15-G
CURB RAMP AND DETECTABLE WARNING DETAILS	R-28-J
DRIVEWAY OPENINGS & APPROACHES AND CONCRETE SIDEWALKS	R-29-I
CONCRETE CURB AND CONCRETE CURB & GUTTER	R-30-G
*GRANULAR BLANKET, UNDERDRAINS, OUTLET ENDINGS FOR UNDERDRAINS, AND SEWER BULKHEADS	*R-80-F
UTILITY TRENCHES	R-83-C
PRECAST CONCRETE END SECTIONS FOR PIPE CULVERT	R-86-F
*SEEDING AND TREE PLANTING	*R-100-I
GRADING CROSS-SECTIONS	R-105-D

*MDOT SPECIAL DETAIL

PROJECT AREA

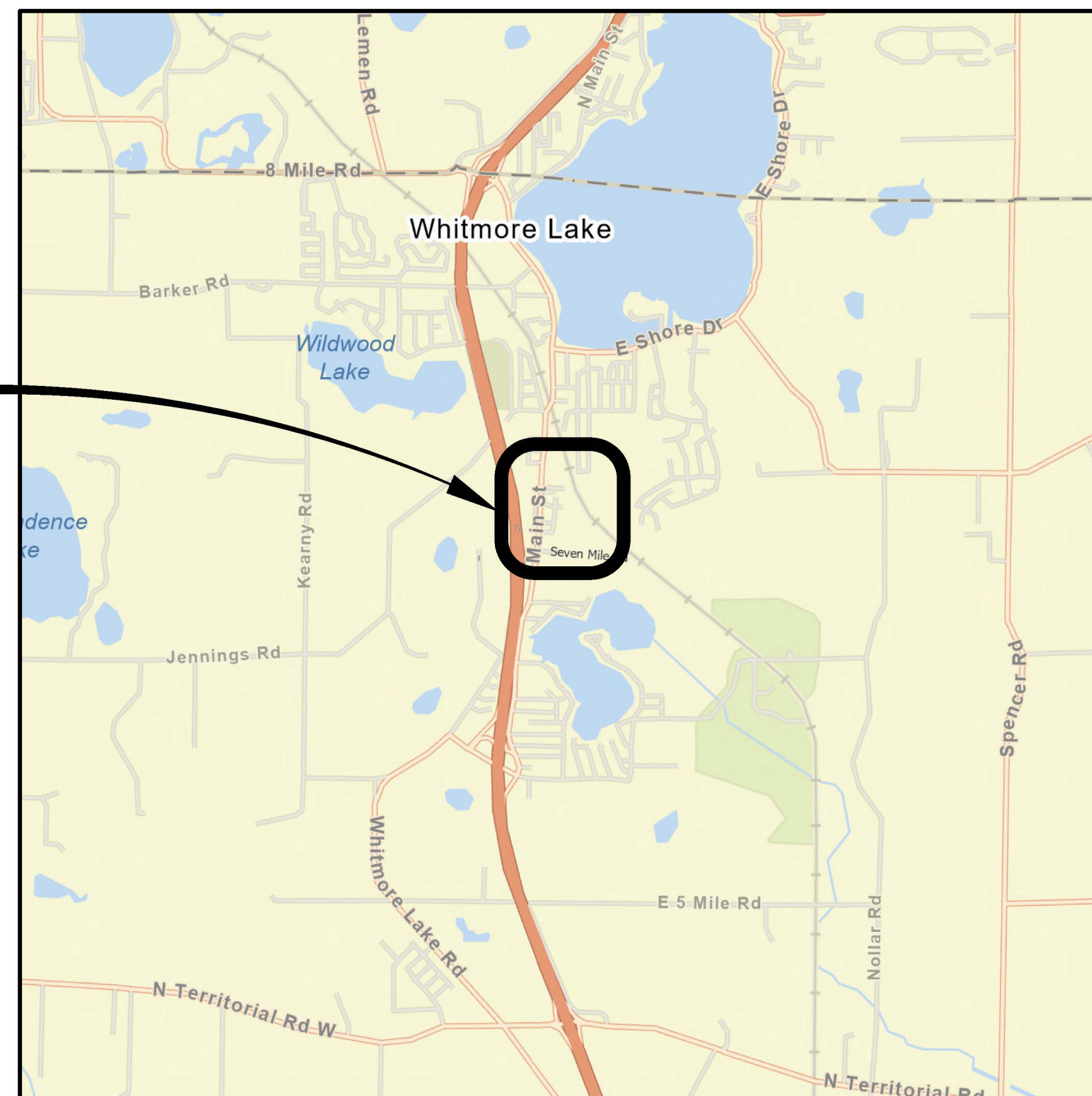

LOCATION MAP
N.T.S.

GENERAL PROVISIONS

THE IMPROVEMENTS COVERED BY THESE PLANS SHALL BE DONE IN ACCORDANCE WITH THE PROPOSAL AND ACCOMPANYING SPECIFICATIONS FOR THIS PROJECT INCLUDING THE 2020 MICHIGAN DEPARTMENT OF TRANSPORTATION STANDARD SPECIFICATIONS FOR CONSTRUCTION, 2011 MICHIGAN MANUAL OF UNIFORM TRAFFIC CONTROL DEVICES, AND THE MICHIGAN DEPARTMENT OF TRANSPORTATION LOCAL AGENCY PROGRAMS GUIDELINES FOR GEOMETRICS DATED 7-24-2017.

THE LOCATION OF ALL PUBLIC UTILITIES SHOWN ON THESE PLANS IS TAKEN FROM THE BEST AVAILABLE DATA. THE TOWNSHIP OF NORTHFIELD WILL NOT BE RESPONSIBLE FOR ANY OMISSION OR VARIATION FROM THE LOCATIONS SHOWN. PURSUANT TO ACTS 173 & 174 OF THE P.A. OF 2013, AS A CONDITION OF THIS CONTRACT, NOTICE SHALL BE GIVEN TO MISS DIG PRIOR TO UNDERGROUND WORK TO BE PERFORMED IN ACCORDANCE WITH THIS CONTRACT, PHONE (800) 482-7171 (OR 811). UTILITY SERVICE CONNECTIONS ARE NOT SHOWN ON THE PLANS AND ARE NOT THE RESPONSIBILITY OF THE TOWNSHIP OF NORTHFIELD.

THE ELEVATIONS SHOWN ON THESE PLANS ARE BASED ON NAVD 1988 VERTICAL DATUM.

APPLICATION DATE	PERMITS	APPROVAL DATE
	WCWRC SOIL EROSION PERMIT	
	WCRC ROW PERMIT	

CONTRACT FOR:
5000 SY OF HMA PAVING, SIDEWALK AND CURB AND GUTTER REPAIRS,
STORM SEWER IMPROVEMENTS, RESTORATION AND PAVEMENT MARKINGS.



PREPARED UNDER THE SUPERVISION OF:

6201051096
Registration No.

THOMAS LENTNER

Date

REVISIONS

PROJECT NO.
0151-23-0030

SHEET NO.
1 OF 9

GENERAL

- THIS PROJECT SHALL BE CONSTRUCTED IN ACCORDANCE WITH THE 2020 MICHIGAN DEPARTMENT OF TRANSPORTATION STANDARD SPECIFICATIONS FOR HIGHWAY CONSTRUCTION EXCEPT AS NOTED HEREIN AND IN THE CONTRACT DOCUMENTS.
- LIMITATIONS ON PRIVATE WORK: DURING CONSTRUCTION OPERATIONS, THE CONTRACTOR SHALL NOT PERFORM WORK BY PRIVATE AGREEMENT WITH PROPERTY OWNERS ADJACENT TO THE PROJECT, UNLESS GIVEN WRITTEN CONSENT OF THE OWNER.
- THE CONTRACTOR SHALL CONDUCT OPERATIONS IN SUCH A MANNER TO COMPLY WITH ALL FEDERAL, STATE, AND TOWNSHIP CODES FOR NOISE LEVELS, VIBRATIONS, OR ANY OTHER RESTRICTIONS WHILE REMOVING PAVEMENT OR FOR ANY OTHER CONSTRUCTION OPERATIONS WITHIN THIS CONTRACT TO BE INCLUDED IN THE RESPECTIVE ITEM OF WORK.
- WHEN THE CONTRACTOR FAILS TO PERFORM THE DUTIES AS CALLED FOR ON THESE PLANS AND IN THE CONTRACT, THE ENGINEER MAY REQUIRE TOWNSHIP FORCES TO PERFORM WORK, WITH OR WITHOUT NOTIFICATION TO THE CONTRACTOR OR THE SURETY. THE CONTRACTOR WILL BE CHARGED EQUIPMENT RENTAL RATES AS ESTABLISHED BY THE TOWNSHIP. TIME CHARGED TO THE CONTRACTOR SHALL BE FROM THE TIME THAT THE WORKFORCE AND EQUIPMENT LEAVE THE TOWNSHIP YARD TO THE TIME THAT THEY RETURN TO THE TOWNSHIP YARD.
- ALL AREAS DISTURBED OUTSIDE THE GRADING LIMITS BY THE CONTRACTOR AND/OR HIS SUBCONTRACTOR SHALL BE SEEDED AS SPECIFIED OR DIRECTED BY THE ENGINEER. NO ADDITIONAL PAYMENT OR COMPENSATION WILL BE ALLOWED FOR THIS ACTIVITY. THE CONTRACTOR SHALL BE RESPONSIBLE FOR ANY DAMAGE TO THE PROPERTY BEYOND THE AREAS OF WORK, INCLUDING EXISTING FENCING, LAWN, TREES, SPRINKLER SYSTEMS, AND SHRUBBERY.
- THE CONTRACTOR SHALL RELOCATE DISTURBED ORNAMENTAL OBJECTS AS DIRECTED BY THE ENGINEER. NO ADDITIONAL PAYMENT OR COMPENSATION WILL BE ALLOWED FOR THIS ACTIVITY.
- DISTURBED AREAS SHALL BE RESTORED IN ACCORDANCE WITH THE PLANS AND SPECIFICATIONS AND AS DIRECTED BY THE ENGINEER. AREAS FOR SEEDING AND SODDING ARE INDICATED ON THE PLANS.
- ALL AREAS DISTURBED BY THE CONTRACTOR AND/OR HIS SUBCONTRACTOR BEYOND THE SLOPE STAKE LINE OF THE PROJECT SHALL BE SODDED OR SEED AS SPECIFIED OR DIRECTED BY THE ENGINEER. NO ADDITIONAL PAYMENT OR COMPENSATION WILL BE ALLOWED FOR THIS ACTIVITY.
- THE CONSTRUCTION OF ALL LONGITUDINAL JOINTS IN THE HMA LEVELING AND WEARING COURSES SHALL BE CONSTRUCTED WITH THE USE OF A JOINT MATCHING SHOE.
- UNTIL THE FINAL ACCEPTANCE OF THE PROJECT, ANY RANDOM, IRREGULARLY CRACKED NEW CONCRETE CURB & GUTTER, CONCRETE PAVEMENT, OR SIDEWALK THAT OCCURS SHALL BE REMOVED AND REPLACED AT THE EXPENSE OF THE CONTRACTOR PRIOR TO OPENING THE PAVEMENT TO TRAFFIC.
- THE CONTRACTOR WILL BE RESPONSIBLE FOR ANY DAMAGE TO EXISTING PUBLIC OR PRIVATE UTILITIES DURING THE CONSTRUCTION OF THIS PROJECT. ADEQUATE CARE SHALL BE TAKEN AT ALL TIMES.
- ALL DRIVEWAY OPENINGS SHALL CONFORM TO MDOT SPECIAL DETAIL R-29-1, DETAIL L OR DETAIL M, EXCEPT THE LAYOUT SHALL BE AS SHOWN ON THE PLANS OR AS DIRECTED BY THE ENGINEER.
- AT LOCATIONS WHERE BARRIER CURBS TERMINATE, THE HEIGHT OF THE BACK OF CURB SHALL TRANSITION FROM FULL HEIGHT TO A HEIGHT OF ONE (1) INCH OVER 10 (10) FEET OR AS DIRECTED BY THE ENGINEER.
- ANY PERMANENT SIGNS REQUIRING RELOCATION DUE TO THE CONTRACTOR'S OPERATIONS SHALL BE SALVAGED AND RESET BY THE CONTRACTOR AT LOCATIONS DESIGNATED BY THE ENGINEER. SIGNS AND POST DAMAGED DURING THE REMOVAL AND STORAGE OPERATION SHALL BE REPLACED WITH NEW SIGNS AND POST BY THE CONTRACTOR AT THEIR SOLE EXPENSE.
- THE CONTRACTOR SHALL NOT PARK ANY VEHICLES OR STORE ANY EQUIPMENT AND MATERIALS ON PRIVATE PROPERTY. ALL WORK SHALL BE CONFINED TO THE CONSTRUCTION LIMITS SHOWN ON THE PLANS UNLESS AUTHORIZED IN ADVANCE BY THE ENGINEER.
- EARTH DISTURBANCE LIMITS FOR THIS PROJECT ARE SHOWN ON THE PLANS. RESTORATION MEASURES HAVE BEEN INCLUDED IN THE PLANS FOR THE APPROVED AREAS OF DISTURBANCE. THE CONTRACTOR SHALL SUBMIT AN EARTH CHANGE PLAN FOR ANY WORK BEYOND THE APPROVED LIMITS TO THE ENGINEER TO REVIEW FOR APPROVAL PRIOR TO THE DISTURBANCE. ALL COSTS FOR OBTAINING AND EXECUTING AN APPROVED EARTH CHANGE PLAN, INCLUDING RESTORATION, SHALL BE AT THE CONTRACTOR'S SOLE EXPENSE.
- THE CONTRACTOR SHALL MAINTAIN ACCESS FOR POSTAL SERVICE AND REFUSE COLLECTION TO ALL PROPERTIES AT ALL TIMES. ACCESS SHALL ALSO BE MAINTAINED FOR EMERGENCY SERVICES, INCLUDING POLICE, FIRE AND EMERGENCY RESPONSE PERSONNEL AND EQUIPMENT, AT ALL TIMES.

REMOVALS

- SAW CUTTING FOR PAVEMENT REMOVAL AS SHOWN ON THE PLANS OR AS DIRECTED BY THE ENGINEER SHALL BE TO THE DEPTH REQUIRED FOR PROPER REMOVAL OF PAVEMENTS OR CURB.
- SAWING DEPTH SHALL BE ADEQUATE TO PREVENT SPALLING, CHIPPING, OR DAMAGE TO EXISTING PAVEMENT EDGES LEFT IN PLACE AS DIRECTED BY THE ENGINEER.
- REMOVALS SHALL BE DONE AS SHOWN ON THE PLANS OR AS DIRECTED BY THE ENGINEER IN FIELD.
- SIDEWALK REMOVAL LIMITS SHALL BE TO THE NEAREST PANEL. PARTIAL PANEL REMOVALS ARE NOT ACCEPTABLE, UNLESS APPROVED BY THE ENGINEER.
- CURB SECTION REMOVALS SHALL BE TO THE NEAREST JOINT. PARTIAL CURB SECTION REMOVALS ARE NOT ACCEPTABLE.
- THE CONTRACTOR SHALL REMOVE THE EXISTING PAVEMENT SURFACE, AS DIRECTED BY THE ENGINEER, TO A SUFFICIENT DEPTH IN ORDER TO CONSTRUCT THE PROPOSED PAVEMENT CROSS-SECTION.
- PAVEMENT REMOVAL AS SHOWN ON THE PLANS SHALL BE AT THE DISCRETION OF THE ENGINEER. IF IN HIS/HER JUDGEMENT, AREAS OF PAVEMENT MAY BE LEFT IN PLACE, OR ADDITIONAL AREAS ADDED, TO PROVIDE THE PROPER CROSS-SECTION AND BASE, ADJUSTMENTS CAN BE MADE IN THE QUANTITIES.
- SAW CUTS ARE NOT PAID FOR SEPARATELY BUT SHALL BE INCLUDED IN THE REMOVAL ITEMS.
- ALL SIGN SALVAGES SHALL BE RESET IMMEDIATELY.

- MISS DIG RULES APPLY PRIOR TO SAW CUTTING AND REMOVAL IF SHALLOW LEADS ARE EXPECTED OR ENCOUNTERED, HAND DIGGING OR POT HOLING OUTSIDE OF THE PAVEMENT, BEHIND THE SECTION OF CURB REMOVAL SHALL BE CONDUCTED AT NO ADDITION EXPENSE TO THE OWNER.

UTILITY NOTES

- FOR PROTECTION OF UNDERGROUND UTILITIES AND CONFORMANCE WITH PUBLIC ACT 53, 1974, THE CONTRACTOR SHALL DIAL 1-800-482-7171 OR 811 A MINIMUM OF THREE FULL WORKING DAYS, EXCLUDING SATURDAYS, SUNDAYS AND HOLIDAYS, PRIOR TO BEGINNING EACH EXCAVATION IN AREAS WHERE PUBLIC UTILITIES HAVE NOT BEEN PREVIOUSLY LOCATED. MEMBERS OF THE "MISS DIG" ALERT SYSTEM WILL BE ROUTINELY NOTIFIED. THIS DOES NOT RELIEVE THE CONTRACTOR OF THE RESPONSIBILITY OF NOTIFYING UTILITY OWNERS WHO MAY NOT BE PART OF THE "MISS DIG" ALERT SYSTEM.
- THE CONTRACTOR WILL BE RESPONSIBLE FOR ANY DAMAGE TO EXISTING PUBLIC OR PRIVATE UTILITIES DURING THE CONSTRUCTION OF THIS PROJECT. ADEQUATE CARE SHALL BE TAKEN AT ALL TIMES.
- THE LOCATIONS SHOWN FOR ALL PUBLIC UTILITIES, INCLUDING WATER SERVICE AND SANITARY SEWER LEADS ARE BASED ON BEST AVAILABLE INFORMATION. NO GUARANTEE IS MADE REGARDING THE ACCURACY OF THIS INFORMATION. THE CONTRACTOR SHALL PERFORM HIS OWN INVESTIGATION(S) IF HE DESIRES TO IN PERFORMING THE WORK OF THIS PROJECT. PAYMENT FOR "EXPLORATORY EXCAVATION, TRENCH WILL NOT BE PAID FOR UNLESS APPROVED IN ADVANCE BY THE ENGINEER.
- ALL UTILITY WORK, INCLUDING STORM SEWER, SANITARY SEWER AND WATER MAIN, SHALL BE PERFORMED IN ACCORDANCE WITH THE NORTHFIELD TOWNSHIP STANDARD DETAILS.
- THE CONTRACTOR SHALL PROVIDE A MINIMUM 48-HOUR WRITTEN NOTICE TO ALL PROPERTY OWNERS PRIOR TO THE CLOSURE OF DRIVEWAYS OR THE INTERRUPTION OF TOWNSHIP WATER SERVICE IN THE EVENT OF A WATER MAIN SHUT-DOWN.
- THE CONTRACTOR SHALL NOTE THAT THERE ARE SELECTED LOCATIONS WHERE STORM STRUCTURES ARE BEING REMOVED AND REPLACED SO AS TO ALIGN WITH THE CONSTRUCTION OF NEW CURB OR ALLOW FOR THE PLACEMENT OF CONCRETE SPILLWAYS. AT THESE LOCATIONS, THERE MAY BE INSTANCES WHERE THE WORK MAY NEED TO BE MODIFIED BY THE ENGINEER TO DEAL WITH SPECIFIC SITE CONDITIONS, INCLUDING ADJUSTING THE LOCATION AND/OR SPECIFIC WORK THAT WILL NEED TO BE PERFORMED. IF THIS IS REQUIRED IN THE OPINION OF THE ENGINEER, ALL WORK WILL BE PERFORMED IN ACCORDANCE WITH THE CONTRACT DOCUMENTS AND PAID FOR AT THE UNIT PRICE(S) FOR THE ACTUAL WORK PERFORMED.
- THE CONTRACTOR SHALL NOTE THAT SELECTED LOCATIONS ARE BEING IDENTIFIED FOR INSTALLATION OF "SUBGRADE UNDERDRAIN, 6 INCH." UNLESS OTHERWISE SPECIFIED ON THE PLANS OR AS DIRECTED BY THE ENGINEER, AT THESE LOCATIONS, PIPE SEGMENTS EQUALING 25 FEET OF 6-INCH SUBGRADE UNDERDRAIN SHALL BE INSTALLED. THIS PROJECT IS NOT PROPOSING THE CONSTRUCTION OF "CONTINUOUS" SUBGRADE UNDERDRAIN.
- WHERE STORM SEWER INLETS ARE TO BE PLACED IN F2 CURB AND GUTTER, EAST JORDAN IRON WORKS 7045 CASTINGS AND TYPE "M2" SINUSOIDAL COVERS ARE TO BE USED. AT ALL OTHER LOCATIONS WHERE INLETS ARE TO BE CONSTRUCTED, EAST JORDAN IRON WORKS 5080 CASTINGS AND TYPE "M2" SINUSOIDAL COVERS ARE TO BE USED.
- THE RECONSTRUCTION OF STRUCTURES, BEYOND "STRUCTURE ADJUSTMENT", SHALL BE AS DIRECTED BY THE ENGINEER.

FLAGGING OPERATIONS

THE CONTRACTOR AND ANY SUBCONTRACTORS WHO WILL BE USING A FLAGGING OPERATION FOR THIS PROJECT SHALL BE REQUIRED TO PROVIDE SATISFACTORY DOCUMENTATION PROVING THAT THEY HAVE MET THE MINIMUM REQUIREMENTS SET FORTH IN SECTION 812 OF THE 2020 DOT STANDARD SPECIFICATIONS FOR CONSTRUCTION. FAILURE TO PROVIDE DOCUMENTATION WILL RESULT IN THE ROAD AUTHORITY WITHHOLDING PAYMENT FOR FLAGGING OPERATIONS. THE CONTRACTOR SHALL FOLLOW THE TRAFFIC CONTROL MEASURES OUTLINED BY THE MDOT PLAN M0140a.

TREE PRESERVATION & REMOVAL

TREE REMOVAL SHALL NOT COMMENCE IN ANY GIVEN AREA UNTIL AFTER APPROVAL TO DO SO IS GIVEN BY THE ENGINEER. TREES REMOVED BY THE CONTRACTOR THAT WERE NOT CLEARLY MARKED AND INTENDED FOR REMOVAL SHALL BE REPLACED WITH 2 1/2" TO 3" DIAMETER PLANTINGS OF A SIMILAR SPECIES AT THE CONTRACTOR'S EXPENSE. REPLACEMENT TREES SHALL BE PROVIDED SUCH THAT THE SUM OF THE DIAMETERS OF THE REPLACEMENT TREES EQUALS THE DIAMETER OF THE TREES REMOVED. TEMPORARY FENCE SHALL BE ERRECTED AROUND TREES THAT ARE TO BE SAVED PRIOR TO THE START OF CONSTRUCTION. NO EQUIPMENT, REMOVAL DEBRIS, LITTER ETC. SHALL BE STORED WITHIN DRIP LINE OF EXISTING TREES TO REMAIN. FOR EXISTING TREES TO BE PRESERVED, ANY WORK REQUIRED WITHIN THE DRIP LINE OF THE TREE SHALL BE DONE BY HAND SO AS TO ENSURE NO OR MINIMAL DISTURBANCE AND COMPACTION TO EXISTING SURFACE ROOTS OF TREE.

HAND FINISHING

HAND FINISHING OF CONCRETE POURS TO BE STRUCK OFF AND CONSOLIDATED BY HAND METHODS WILL BE PERMITTED ON VARIABLE WIDTH LANES AND LANES FORMED BY FLEXIBLE FORMS FOR SHORT RADIUS CURVES AS DIRECTED BY THE ENGINEER.

SOIL EROSION MEASURES

PLACE PERMANENT SEED AND MULCH AS SOON AS POSSIBLE. CRITICAL DITCH GRADES SHOULD BE PROTECTED WITH EITHER SOD OR SEED/MULCH AS DIRECTED BY THE ENGINEER. REFER TO PLANS AND STANDARD DETAILS FOR SOIL EROSION DETAILS.

CONCRETE PAVEMENT/CURB AND GUTTER

THE CONCRETE MIX SHALL BE GRADE P1 IN ACCORDANCE WITH SECTION 601 OF THE 2020 MDOT STANDARD SPECS FOR CONSTRUCTION.

ADJUSTING MONUMENT BOXES

IT IS THE INTENT THAT ALL GOVERNMENT CORNERS ON THIS PROJECT BE PRESERVED AND THAT, WHERE NECESSARY, MONUMENT BOXES BE PLACED OR ADJUSTED, WHETHER SHOWN OR NOT. PRESERVING MONUMENT BOXES SHALL BE PERFORMED IN ACCORDANCE WITH THE MICHIGAN DEPARTMENT OF TRANSPORTATION 2020 STANDARD SPECIFICATIONS FOR CONSTRUCTION.

DUST CONTROL

THE CONTRACTOR IS RESPONSIBLE FOR CONTROLLING DUST ON THE PROJECT BY SPRAYING WATER ON ANY AGGREGATE OR UNRESTORED SURFACES AS NEEDED OR AS REQUESTED BY THE ENGINEER. ALL COSTS FOR THIS OPERATION SHALL BE INCLUDED CONTRACT PAY ITEMS AND WILL NOT BE PAID FOR SEPARATELY.

SIDEWALK

ADDITIONAL SIDEWALK MAY BE ADDED BY THE ENGINEER TO THE SCOPE OF THE PROJECT PRIOR TO CONSTRUCTION. ANY SIDEWALK DAMAGED BY THE CONTRACTOR NOT MARKED FOR REMOVAL ON THE PLANS SHALL BE REPLACED AT THE COST OF THE CONTRACTOR.

UTILITIES

- THE FOLLOWING UTILITY COMPANIES HAVE FACILITIES WITHIN THE PROJECT LIMITS:
- FOR STORM SEWER: NORTHFIELD TOWNSHIP
ATT: BRIAN MACDONALD
PH: 734-449-2880 EXT. 161
 - FOR CABLE TELEVISION: CHARTER COMMUNICATIONS
ATTN: CHRISTIE DOLE
PH: (800) 242-8511
TWC_UTILITY_REQUESTS@CCISYSTEMS.COM
 - FOR ELECTRIC: DETROIT EDISON
ATTN: STEVEN E FACINE
PH: (313) 407-5364
 - FOR FIBER OPTICS: CHARTER COMMUNICATIONS
ATTN: CHRISTIE DOLE
PH: (800) 242-8511
TWC_UTILITY_REQUESTS@CCISYSTEMS.COM
 - FOR GAS: CONSUMERS ENERGY
PH: (800) 482-7171

NOTE: REFER TO SHEET 5 (SOIL EROSION & SEDIMENTATION CONTROLS) FOR THE LOCATIONS OF THE INLET PROTECTION FABRIC DROPS.

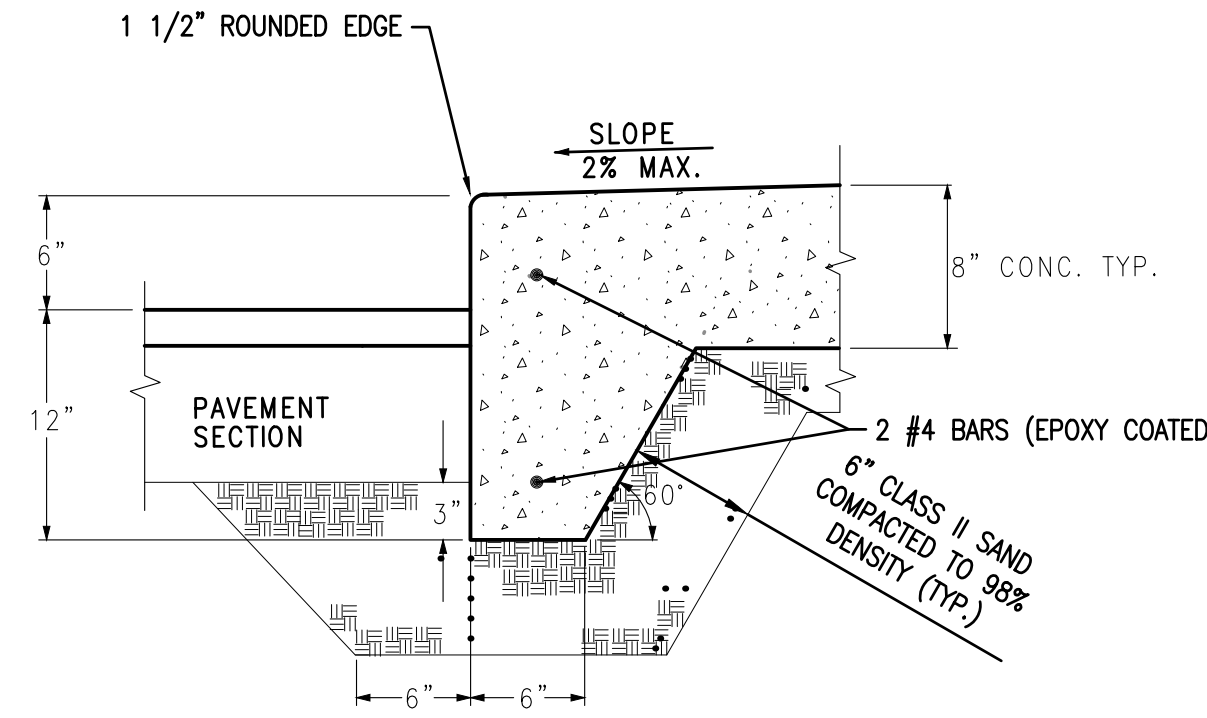

SIDEWALK DETAIL

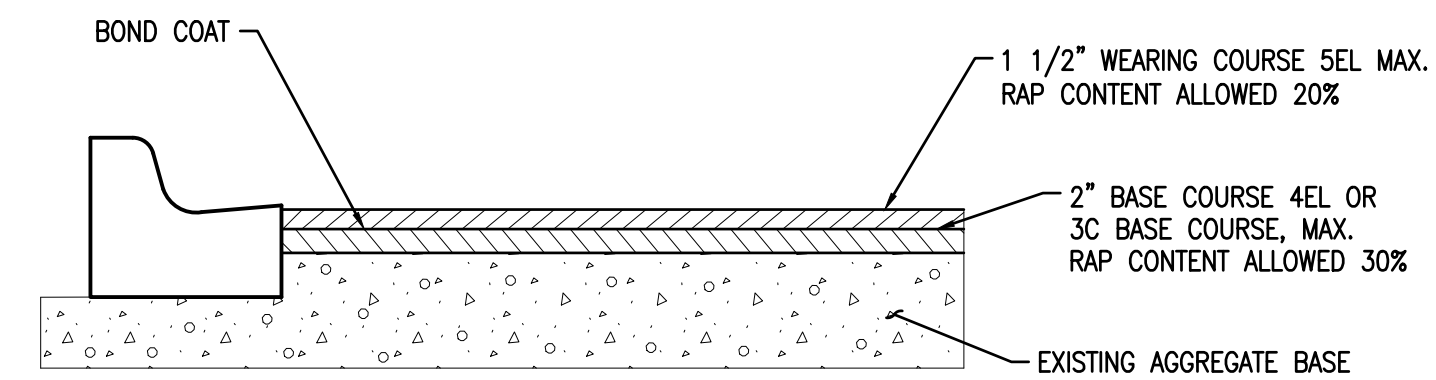

REGULAR DUTY PAVEMENT

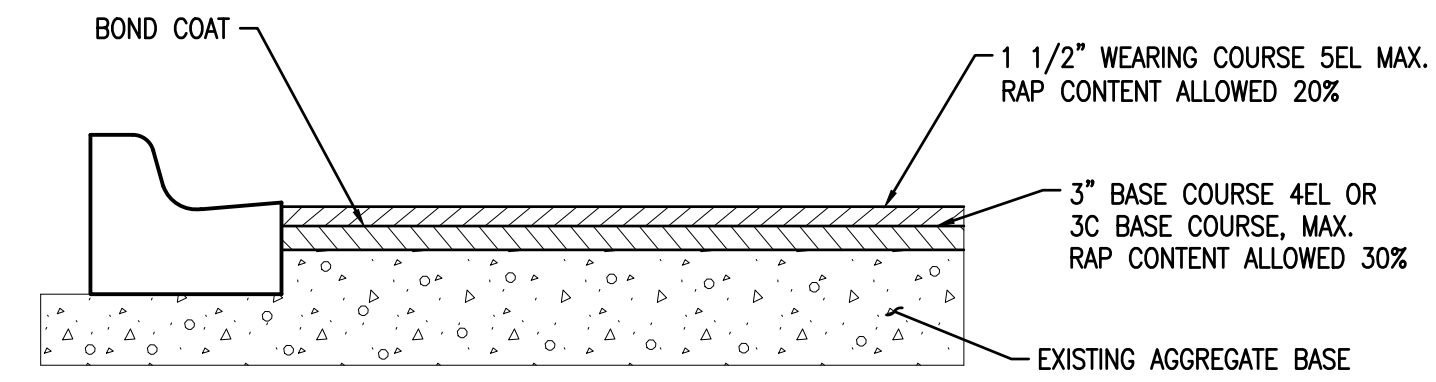

HEAVY DUTY PAVEMENT

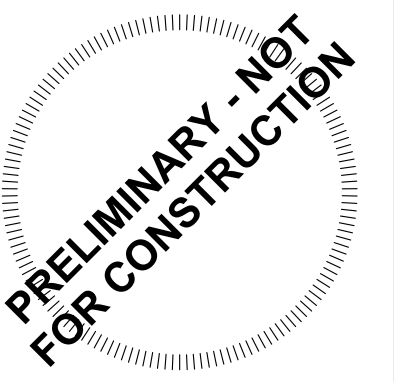

ISSUED FOR:	ISSUE DESCRIPTION	DATE
REVISION	DESCRIPTION	

PROJECT NUMBER: 0151-23-0020
 PM: []
 IN: []
NORTHFIELD TOWNSHIP
NORTHFIELD TOWNSHIP HALL
 8360 MAIN ST
GENERAL NOTES

DRAWING PATH: P:\0128_016501615\230030_Township_Hall_LetDrawings\Civil\Misc\230030\LEG_NOT.dwg Feb-23-2024 - 10:33am

COPYRIGHT 2023 OHM ADVISORS. ALL DRAWINGS AND WRITTEN MATERIALS APPEARING HEREIN CONSTITUTE THE ORIGINAL AND UNPUBLISHED WORK OF OHM ADVISORS AND THE SAME MAY NOT BE DUPLICATED, DISTRIBUTED, OR DISCLOSED WITHOUT PRIOR WRITTEN CONSENT OF OHM ADVISORS.

WATER & SEWER UTILITY SYMBOLS

EXISTING

- ST STORM MANHOLE
- SQUARE CATCH BASIN
- ⊕ ROUND CATCH BASIN
- == CULVERT
- ⊕ CULVERT W/O END SECTION
-) CULVERT W/END SECTION
- S SANITARY MANHOLE
- ⊙ CLEAN OUT
- ⊗GW GATE VALVE & WELL
- GATE VALVE & BOX
- ⊕ W WATER STOP BOX
- ⊕ FIRE HYDRANT
- ⊕ MP METER PIT
- ⊕ WATER METER
- ⊕ SH SPRINKLER HEAD
- ⊕ IRRIGATION VALVE

PROPOSED

- STORM MANHOLE
- INLET/CATCH BASIN
-) CULVERT END SECTION
- SANITARY MANHOLE
- ⊗GV&W GATE VALVE & WELL
- ⊗GV&B GATE VALVE & BOX
- ⊗TSV&W TAPPING SLEEVE VALVE & WELL
- ⊗TSV&B TAPPING SLEEVE VALVE & BOX
- ⊕ FIRE HYDRANT

REAL ESTATE SYMBOLS

- ↔ CONTIGUOUS PROPERTY SYMBOL
- ⊗ PARCEL NUMBER BOX
- ⊗ NO ROW IMPACTS

MISCELLANEOUS UTILITY SYMBOLS

EXISTING

- ⊕ GUY WIRE
- ⊕ GP GUY POLE
- ⊕ U UTILITY POLE
- ⊕ UTILITY POLE W/LIGHT
- ⊕ LIGHT/DECOR LAMP POLE
- ⊕ FLOOD LIGHT
- ⊕ GAS VALVE
- ⊕ GAS VENT
- ⊕ GAS METER
- ⊕ GAS RISER
- ⊕ TRAFFIC SIGNAL
- ⊕ PEDESTRIAN RISER
- ⊕ TRANSFORMER PAD
- ⊕ U PRIVATE UTILITY MANHOLE
- ⊕ R RAILROAD CROSSING
- ⊕ E ELECTRIC METER
- ⊕ PB PHONE BOOTH
- ⊕ TS TRAFFIC SIGNAL CONTROLLER
- ⊕ HAND HOLE
- ⊕ E ELECTRIC RISER
- ⊕ T TELEPHONE RISER
- ⊕ C CABLE TV RISER
- ⊕ W MONITORING WELL
- ⊕ UNDERGROUND MARKER

MISCELLANEOUS SYMBOLS

EXISTING

- ⊕ RIPRAP
- ⊕ SIGN
- ⊕ FLOW DIRECTION
- ⊕ STUMP
- ⊕ WETLAND
- ⊕ CONIFEROUS TREE } CL 1 1" TO 5"
- ⊕ DECIDUOUS TREE } CL 2 6" TO 17"
- ⊕ CONIFEROUS SHRUB } CL 3 18" TO 35"
- ⊕ } CL 4 36" AND UP
- ⊕ DECIDUOUS SHRUB
- ⊕ SB# SOIL BORING
- ⊕ SECTION CORNER
- ⊕ MON MONUMENT
- ⊕ IRON ROD/PIPE
- ⊕ PK PK NAIL
- ⊕ BM# BENCHMARK
- ⊕ TP# TRAVERSE POINT
- ⊕ MAIL/NEWSPAPER BOX
- ⊕ FLAG POLE
- ⊕ POST

HAZARDOUS OR FLAMMABLE MATERIAL USED WITH UNDERGROUND GAS & ELECTRICAL LINES

CAUTION - CRITICAL UNDERGROUND UTILITY USED WITH TELEPHONE & FIBER OPTIC LINES

PROPOSED

- ⊕ RIPRAP
- ⊕ SIGN
- ⊕ FLOW DIRECTION
- ⊕ STRUCTURE NUMBER } WM SAN STM
- ⊕ ADA SIDEWALK RAMP

UTILITY PATTERN

EXISTING

- ⊕ ELEC ELECTRICAL *
- ⊕ 6" (COMPANY) GAS GAS\OIL
- ⊕ (COMPANY) CABLE/TEL CABLE/TELEPHONE *
- ⊕ FIBER OPTIC FIBER OPTIC *
- ⊕ 12" WM WATER
- ⊕ 12" SAN SANITARY
- ⊕ 12" STM STORM

PROPOSED

- ⊕ 12" STORM/SANITARY/WATER
 - ⊕ 12" PRIMARY UTILITY WILL HAVE A CONTINUOUS LINESYLE, WITH THE SECONDARY UTILITY MATCHING ITS RESPECTIVE EXISTING UTILITY LINESYLE
- *O.H. = OVERHEAD , U.G. = UNDERGROUND

ROW PATTERN

EXISTING

- ⊕ ROW ROW
- ⊕ SECTION SECTION
- ⊕ PROPERTY/PARCEL PROPERTY/PARCEL

PROPOSED

- ⊕ ROW ROW

TOPO PATTERN

EXISTING

- ⊕ HEDGE/TREE HEDGE/TREE
- ⊕ FENCE FENCE
- ⊕ GUARDRAIL GUARDRAIL
- ⊕ CENTERLINE OF DITCH CENTERLINE OF DITCH
- ⊕ RAILROAD RAILROAD
- ⊕ WETLAND/EDGE OF WATER WETLAND/EDGE OF WATER

PROPOSED

- ⊕ GRADING LIMIT (SLOPE STAKE) GRADING LIMIT (SLOPE STAKE)
- ⊕ CENTERLINE OF DITCH CENTERLINE OF DITCH
- ⊕ GUARDRAIL GUARDRAIL
- ⊕ FENCE FENCE

REMOVAL LEGEND

- ⊕ SIDEWALK REMOVAL SIDEWALK REMOVAL
- ⊕ HMA SURFACE REMOVAL HMA SURFACE REMOVAL
- ⊕ PAVEMENT REMOVAL PAVEMENT REMOVAL
- ⊕ COLD MILLING HMA SURFACE COLD MILLING HMA SURFACE
- ⊕ SAW AND SEAL JOINTS SAW AND SEAL JOINTS
- ⊕ EXCAVATION, EARTH, MODIFIED EXCAVATION, EARTH, MODIFIED
- ⊕ CURB AND GUTTER, REM CURB AND GUTTER, REM
- ⊕ TREE, REM TREE, REM
- ⊕ S-SALVAGE S-SALVAGE
- ⊕ B-BULKHEAD B-BULKHEAD
- ⊕ A-ABANDON A-ABANDON
- ⊕ R-REMOVE R-REMOVE
- ⊕ ADJ-ADJUST ADJ-ADJUST
- ⊕ REL-RELOCATE REL-RELOCATE
- ⊕ REC-RECONSTRUCT REC-RECONSTRUCT
- ⊕ R B/O-REMOVE BY OTHERS R B/O-REMOVE BY OTHERS
- ⊕ ADJ B/O-ADJUST BY OTHERS ADJ B/O-ADJUST BY OTHERS
- ⊕ REL B/O-RELOCATE BY OTHERS REL B/O-RELOCATE BY OTHERS

IF NECESSARY FOR CLARITY

- ⊕ SALVAGE SALVAGE
- ⊕ BULKHEAD BULKHEAD
- ⊕ ABANDON ABANDON
- ⊕ CLEARING CLEARING
- ⊕ REMOVE REMOVE
- ⊕ RELocate RELOCATE
- ⊕ RECONSTRUCT RECONSTRUCT
- ⊕ REL B/O RELOCATE BY OTHERS
- ⊕ ADJ B/O ADJUST BY OTHERS

SPECIAL LEGEND



PRELIMINARY - NOT FOR CONSTRUCTION

ISSUED FOR: ISSUE DESCRIPTION
 REVISION DESCRIPTION
 DATE

PROJECT NUMBER: 0151-23-0230
 PM: _____
 IN: _____
NORTHFIELD TOWNSHIP
NORTHFIELD TOWNSHIP HALL
 8360 MAIN ST
LEGEND

DRAWING PATH: P:\0126_01650151230030_Township_Hall_LotDrawings\CivilPlans_Const\230300CON.dwg Feb 23, 2024 - 10:33am

MAIN STREET

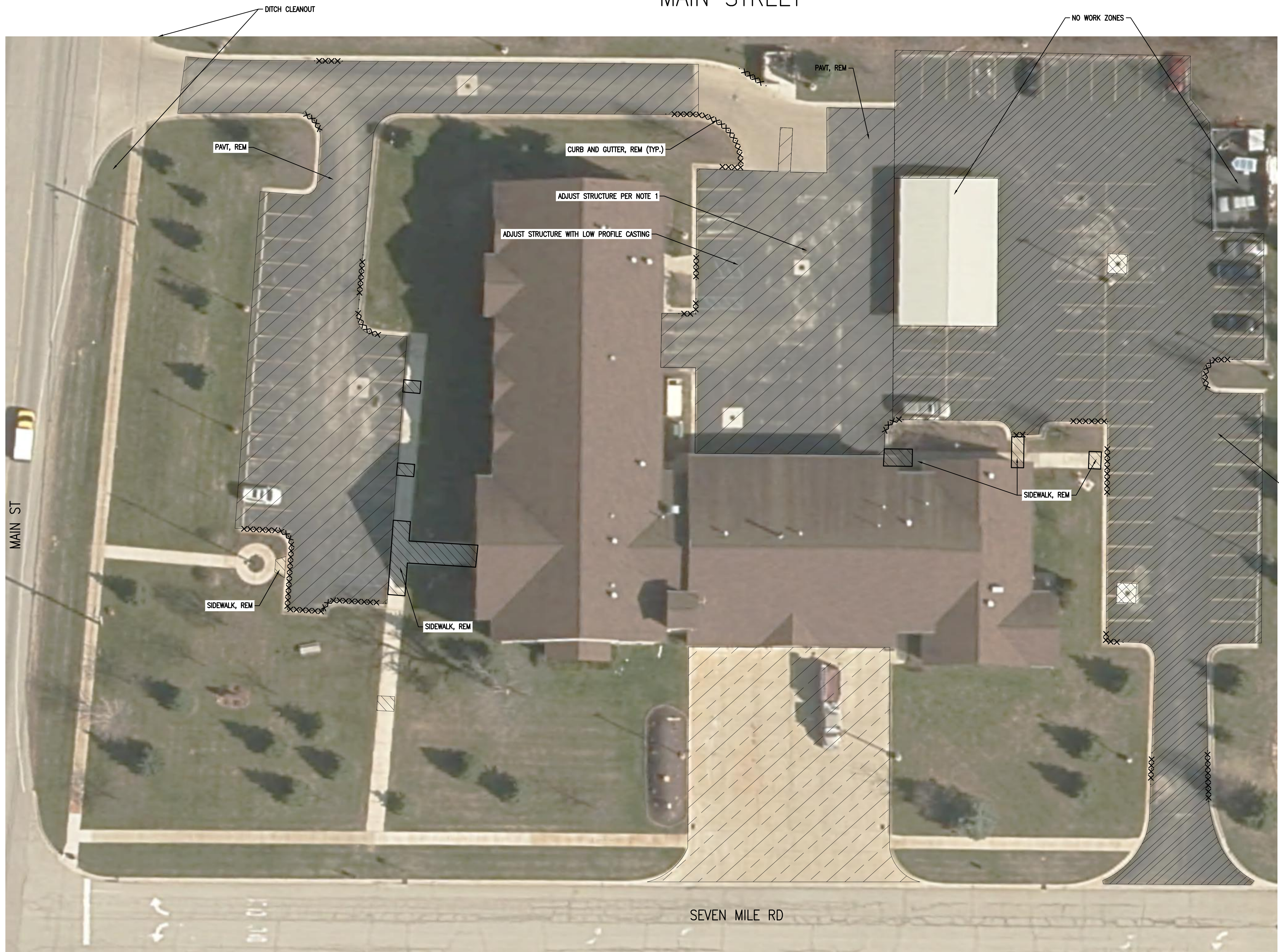
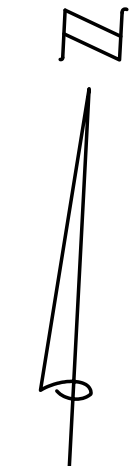
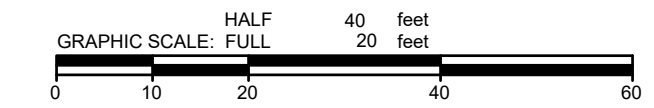

REMOVAL LEGEND

- SIDEWALK REMOVAL
- HMA SURFACE REMOVAL
- PAVEMENT REMOVAL
- COLD MILLING HMA SURFACE
- SAW AND SEAL JOINTS
- EXCAVATION, EARTH, MODIFIED
- CURB AND GUTTER, REM

PRELIMINARY - NOT FOR CONSTRUCTION

- NOTES:**
- CONTRACTOR TO VERIFY STRUCTURE SIZE AND EXISTING FLATTOP BEFORE ORDERING ANY PARTS. CONTRACTOR TO REMOVE EXISTING 36 IN DEEP FLATTOP AND REPLACE WITH 24 IN DEEP FLATTOP.
 - IT IS ANTICIPATED THAT PAVING OPERATIONS WILL BE BROKEN UP INTO TWO PHASES. COORDINATION WITH THE FIRE DEPARTMENT, POLICE DEPARTMENT AND TOWNSHIP OFFICES.

QUANTITIES THIS SHEET

TOTAL	UNIT	DESCRIPTION
300	Ft	Curb and Gutter, Rem
138	Syd	Sidewalk, Rem
2730	Syd	Pavt, Rem, Modified
1	LSUM	Dr Str Flattop, Rem and Replace, 72 in
1	Sta	Ditch Cleanout
2664	Syd	Station Grading
1	Ea	Dr Str Cover, Low Profile
8	Ea	Structure Cover, Adj, Case 1, Conc Collars
2824	Syd	Cold Milling HMA Surface
296	Ton	HMA, 3C
613	Ton	HMA, 5EL
11	Syd	Pavt Repr, Nonrein Conc, 8 inch
1396	Ft	Saw and seal concrete pavement joints.
300	Ft	Curb and Gutter, Conc, Det F4
561	Sft	Sidewalk, Conc, 4 inch
50	Sft	Curb Ramp, Conc, 4 inch
392	Sft	Sidewalk, Conc, Thickened Edge
409	Syd	Slope Restoration, Non-Freeway, Type B



ISSUED FOR:	ISSUE DESCRIPTION	DATE
REVISION	DESCRIPTION	DATE

NORTHFIELD TOWNSHIP
NORTHFIELD TOWNSHIP HALL
 8360 MAIN ST
REMOVAL AND CONSTRUCTION PLAN

PROJECT NUMBER: 0151-23-0230
 PM: [blank]
 IN: [blank]

COPYRIGHT 2023 OHM ADVISORS. ALL DRAWINGS AND WRITTEN MATERIALS APPEARING HEREIN CONSTITUTE THE ORIGINAL AND UNPUBLISHED WORK OF OHM ADVISORS AND THE SAME MAY NOT BE DUPLICATED, DISTRIBUTED, OR DISCLOSED WITHOUT PRIOR WRITTEN CONSENT OF OHM ADVISORS.

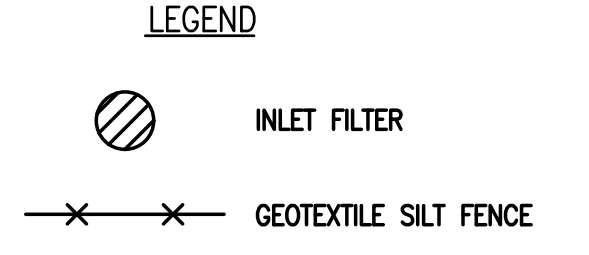
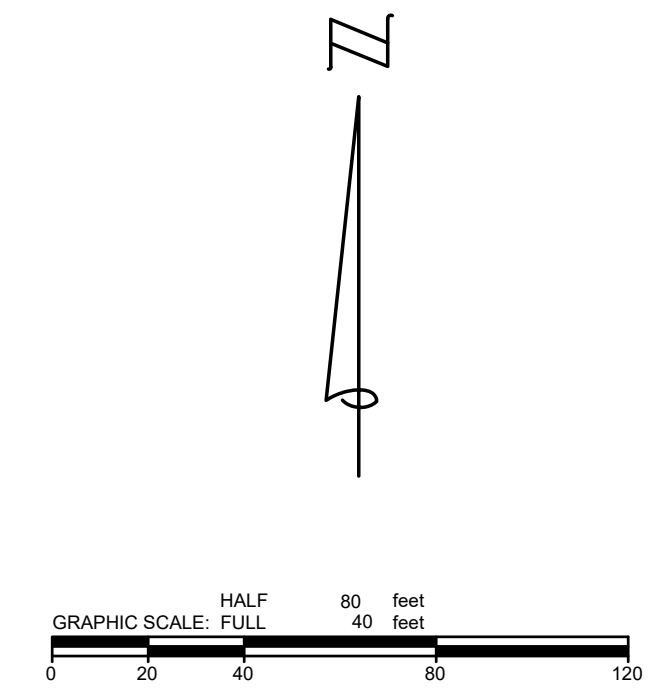

PRELIMINARY - NOT FOR CONSTRUCTION

ISSUED FOR:	ISSUE DESCRIPTION	REVISION	DATE

PROJECT NUMBER: 0151-23-0230
 NORTHFIELD TOWNSHIP
 NORTHFIELD TOWNSHIP HALL
 8360 MAIN ST
 SOIL EROSION AND SEDIMENTATION CONTROL

SITE DATA

SOIL TYPES: (BnB) BOYER LOAMY SAND, 1 TO 6% SLOPES

TEMPORARY SOIL EROSION MEASURES: INLET FILTER

PROXIMITY TO LAKES AND STREAMS: SITE STORM SEWER IS 205 Ft FROM WASHTENAW WATER COUNTY WATER RESOURCES COMMISSION HORSESHOE LAKE OUTLET.

PERMANENT SOIL EROSION MEASURES: 3" TOPSOIL, SEED, FERTILIZER STABILIZED WITH MULCH PAVEMENT

SITE DATA

LOT SIZE: PUBLIC PARCEL - 6.1 ACRES

AREA OF DISTURBANCE: 1.1 ACRES

IMPACTED AREA: PUBLIC ROAD RIGHT OF WAY.

ALL WORK WILL OCCUR WITHIN PUBLIC ROAD RIGHT OF WAY OR A PUBLIC EASEMENT DEDICATED TO THE CITY OF DEXTER.

EROSION CONTROLS MAINTENANCE PLAN

MEASURE	MAINTENANCE SCHEDULE
INLET FILTER	INSTALL IN AT THE START OF CONSTRUCTION PER PLAN. INSPECT WEEKLY OR AFTER EACH RAIN EVENT. REMOVE ACCUMULATED SEDIMENTS.
DUST CONTROL	WATER SHALL BE APPLIED TO EXPOSED AREAS BY THE CONTRACTOR IN THE EVENT OF EXCESSIVE AIRBORNE DUST. DUST CONTROL SHALL BE APPLIED AS DIRECTED BY THE ENGINEER OR CITY PERSONNEL.
VEGETATION (PERM)	TOPSOIL, SEED AND MULCH SHALL BE PLACED UPON THE COMPLETION OF THE WATER MAIN AND ROADWAY CONSTRUCTION. SEED SHALL BE WATERED AND MULCH MAINTAINED UNTIL VIGOROUS TURF GROWTH HAS BEEN ESTABLISHED.

QUANTITIES THIS SHEET

TOTAL	UNIT	DESCRIPTION
9	Ea	Erosion Control, Inlet Protection, Fabric Drop

SOIL EROSION AND SEDIMENTATION CONTROL NOTES

- CONTRACTOR SHALL COMPLY WITH REQUIREMENTS OF THE SOIL EROSION AND SEDIMENTATION CONTROL ACT OF THE STATE OF MICHIGAN, PART 91 OF ACT 451, OF THE PUBLIC ACTS OF 1994 AND THE REQUIREMENTS OF WASHTENAW COUNTY.
- THE CONTRACTOR SHALL CONDUCT OPERATIONS IN A MANNER THAT WILL REDUCE ACCELERATED EROSION TO THE PRACTICAL MINIMUM AND PREVENT DAMAGING SILTATION TO EXISTING SEWERS AND WATER COURSES LEADING FROM THE WORK SITE.
- THE CONTRACTOR SHALL CONDUCT WORK IN SUCH A MANNER AS TO PREVENT THE ENTRY OF FUELS, OILS, BITUMINOUS MATERIALS, CHEMICALS, SEWERAGE OR OTHER HARMFUL MATERIALS INTO NEARBY LAKES AND STREAMS.
- WASTE DISPOSAL AREAS SHALL BE SELECTED BY THE CONTRACTOR WITH FULL CONSIDERATION OF EROSION AND SEDIMENT CONTROL, SELECTION OF DISPOSAL SITE, AND CONTROL OF OPERATIONS, AND THE RESTORATION OF SAID AREAS SHALL BE SUBJECT TO THE APPROVAL OF THE ENGINEER.
- EXCAVATION FROM THE RIGHT-OF-WAY, CHANNELS, OR OTHER MATERIAL SHALL NOT BE DEPOSITED IN OR NEAR RIVERS, STREAMS OR PONDS WHERE IT MAY ENTER THE WATERWAY.
- AT THE COMPLETION OF EACH DAY'S CONSTRUCTION, CARE SHALL BE TAKEN TO ENSURE THAT MINIMAL EROSION WILL OCCUR IN TRENCHES AND TO STOCKPILED MATERIALS UNTIL RESUMPTION OF WORK
- CONTRACTOR SHALL CONFINE OPERATIONS TO THE MINIMUM AMOUNT OF WORKING SPACE PRACTICAL TO MINIMIZE SOIL EROSION.
- THE PROJECT WILL BE CONTINUALLY INSPECTED BY THE ENGINEER FOR EROSION CONTROL COMPLIANCE. DEFICIENCIES WILL BE CORRECTED BY THE CONTRACTOR IMMEDIATELY UPON NOTICE OF SUCH DEFICIENCIES. FAILURE TO CORRECT THE DEFICIENCIES MAY RESULT IN THE ISSUANCE OF A STOP WORK ORDER AND THERE WILL BE NO CONTRACT TIME EXTENSION GRANTED FOR THIS TYPE OF STOPPAGE.
- TEMPORARY SOIL EROSION CONTROL MEASURES CONSISTING OF SILT FENCE, MULCHING, AND TARPING SHALL BE IMPLEMENTED THROUGHOUT THE ENTIRE CONSTRUCTION PHASE OF THE PROJECT, AND SHALL BE REMOVED BY THE CONTRACTOR AFTER THE PERMANENT SOIL EROSION MEASURES HAVE BEEN COMPLETED
- THE CONTRACTOR SHALL INSPECT SILT FENCE AFTER EACH RAIN EVENT AND REPAIR POSTS AND FABRIC THAT HAVE BEEN DAMAGED.
- STRAW MULCH WITH NETTING TIE DOWN, HIGH VELOCITY MULCH BLANKET OR OTHER APPROVED MULCH SHALL BE PLACED ON DISTURBED SLOPES WHERE DIRECTED BY THE ENGINEER.
- PERMANENT SOIL EROSION MEASURES CONSISTING OF THM MIXTURE SEED AND MULCH BLANKET SHALL BE COMPLETED WITHIN 5 CALENDAR DAYS OF FINAL GRADING. IN THE EVENT IT IS NOT POSSIBLE TO PERMANENTLY STABILIZE THE AREA DUE TO SITE CONDITIONS AND/OR SEASONAL LIMITATIONS, THE TEMPORARY MEASURES SHALL REMAIN IN FORCE AND SHALL BE MAINTAINED BY THE CONTRACTOR UNTIL SUCH TIME AS IT IS PRACTICAL TO COMPLETE THE PERMANENT SOIL EROSION CONTROL MEASURES.
- THE ENGINEER SHALL HAVE FULL AUTHORITY TO TEMPORARILY SUSPEND WORK IN THE EVENT THAT ANY OF THE ABOVE REQUIREMENTS ARE NOT BEING MET BY THE CONTRACTOR, OR IF CONDITIONS INDICATE THAT ADDITIONAL TEMPORARY CONTROL MEASURES ARE WARRANTED, IN THE OPINION OF THE ENGINEER.
- PRIOR TO THE START OF WORK, THE CONTRACTOR SHALL INSTALL INLET FILTERS AT ALL INLETS IN THE CONSTRUCTION AREA PER DETAIL DRAWING SI-2 AND SI-4, INLET FILTER. ALL OTHER SESC MEASURES TO BE IN PLACE PRIOR TO START OF CONSTRUCTION.
- THE CONTRACTOR SHALL BE RESPONSIBLE FOR THE MAINTENANCE OF THE TEMPORARY ROAD SURFACE AND SOIL EROSION CONTROL MEASURES WITHIN THE CONSTRUCTION AREA UNTIL THE FULL COMPLETION OF THE PROJECT.
- ALL WORK TO BE COMPLETED WITHIN EXISTING RIGHT-OF-WAY AND/OR EASEMENTS.
- CITY OF DEXTER DEPT OF PUBLIC WORKS (734-426-4572) TO MAINTAIN PERMANENT SOIL EROSION AND SEDIMENTATION CONTROL MEASURES UPON COMPLETION OF PROJECT.



Know what's below.
Call before you dig.

MAIN STREET

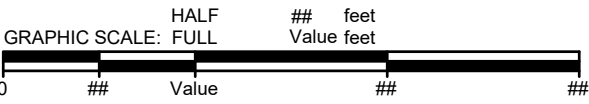

PRELIMINARY - NOT FOR CONSTRUCTION

ISSUED FOR:	ISSUE DESCRIPTION	REVISION	DESCRIPTION	DATE

TOTAL	UNIT	DESCRIPTION
42	Ea	Rem and reset bumper blocks
4	Ea	Sign, Type III, Rem
6	Sr	Sign, Type IIIA
1	LSUM	Pavement Markings



PROJECT NUMBER: 0151-23-0230
 NORTHFIELD TOWNSHIP
 NORTHFIELD TOWNSHIP HALL
 8360 MAIN ST
 PAVEMENT MARKING PLAN

DRAWING PATH: P:\0126_016501615\230030_Township_Hall_LotDrawings\Civil\Non_OHM\230030\REF.dwg Feb 23, 2024, 10:34am

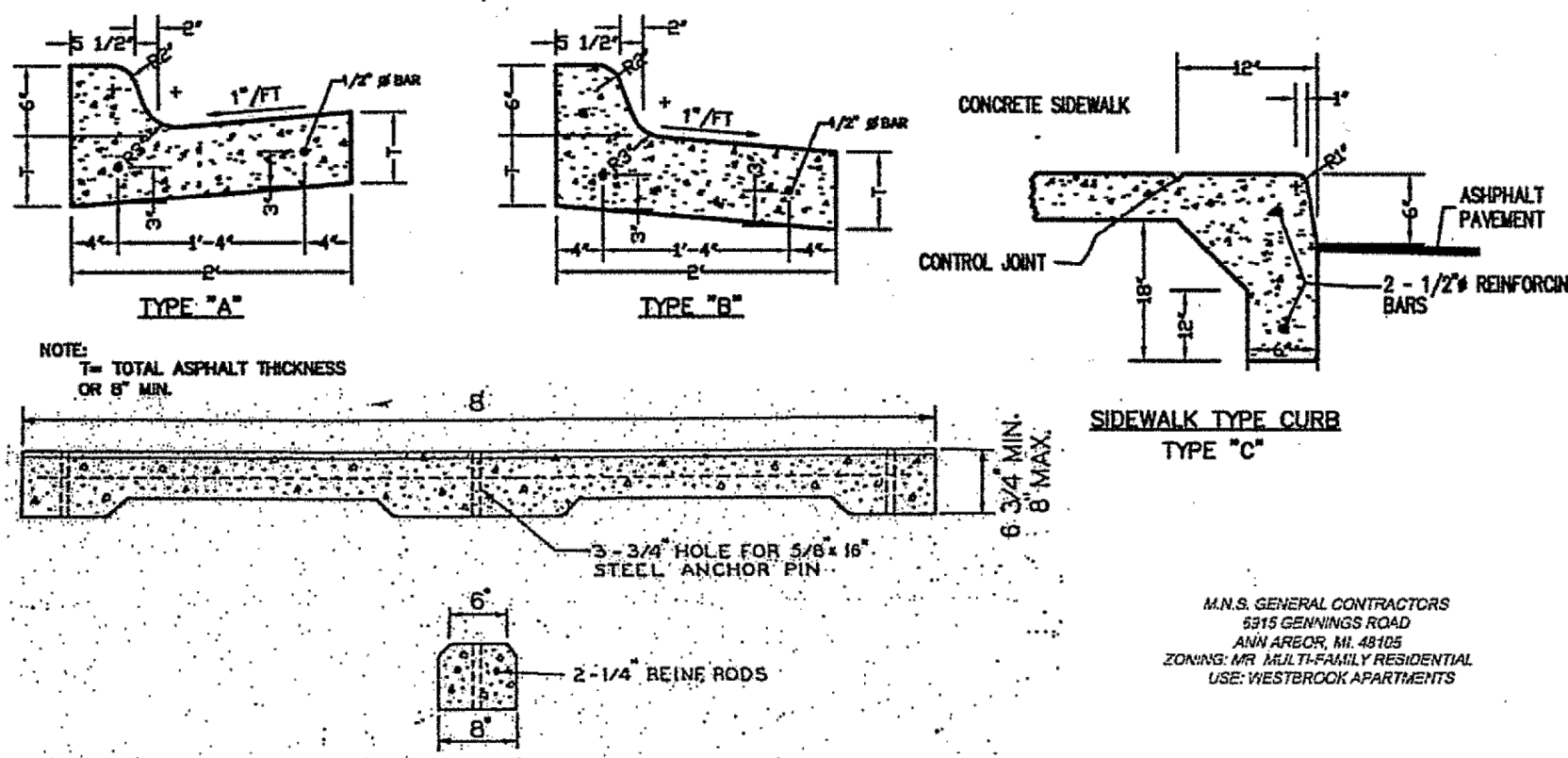
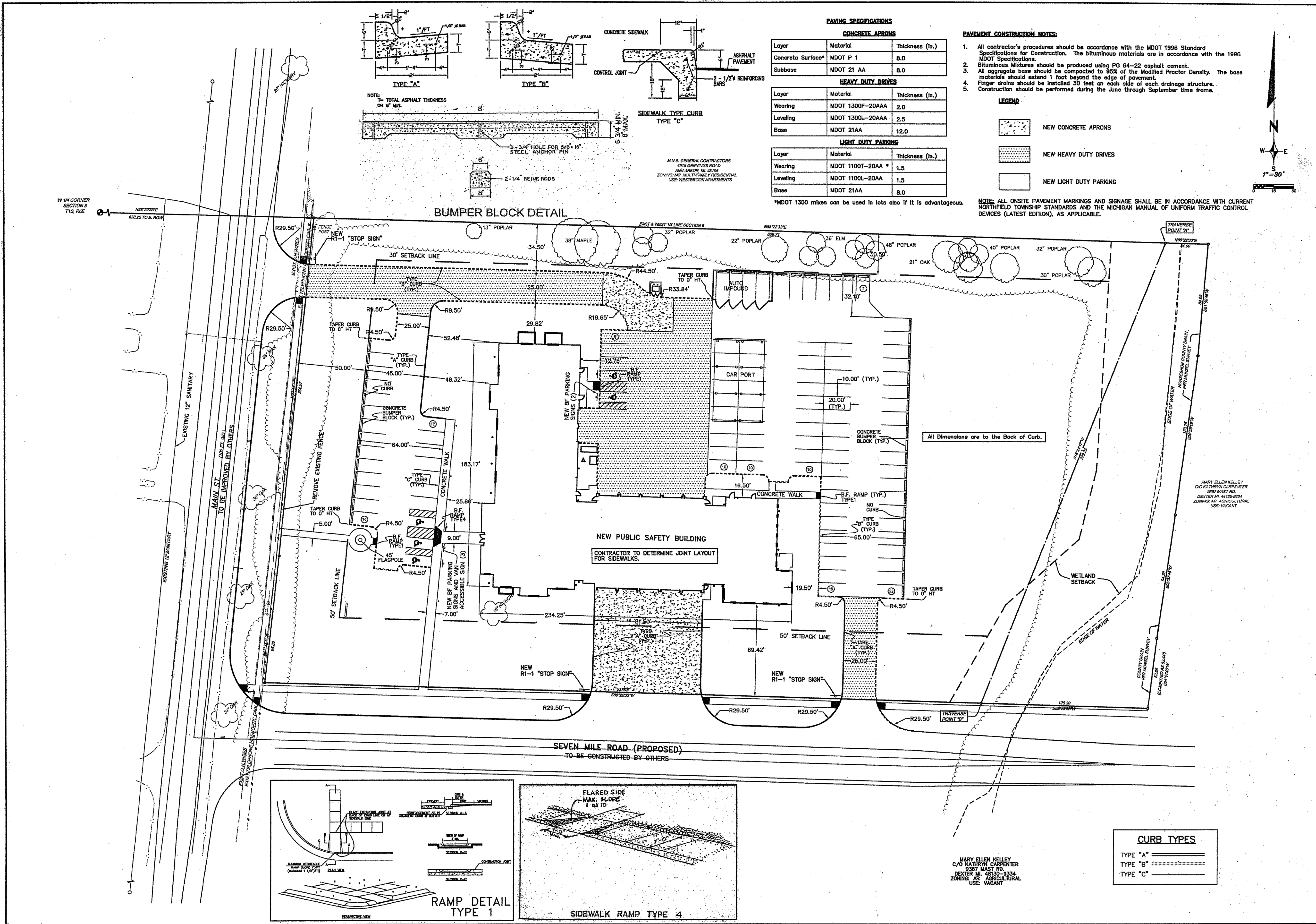

PAVING SPECIFICATIONS

CONCRETE APRONS

Layer	Material	Thickness (in.)
Concrete Surface*	MDOT P 1	8.0
Subbase	MDOT 21 AA	8.0

HEAVY DUTY DRIVES

Layer	Material	Thickness (in.)
Wearing	MDOT 1300F-20AAA	2.0
Leveling	MDOT 1300L-20AAA	2.5
Base	MDOT 21AA	12.0

LIGHT DUTY PARKING

Layer	Material	Thickness (in.)
Wearing	MDOT 1100T-20AA *	1.5
Leveling	MDOT 1100L-20AA	1.5
Base	MDOT 21AA	8.0

*MDOT 1300 mixes can be used in lots also if it is advantageous.

- PAVEMENT CONSTRUCTION NOTES:**
- All contractor's procedures should be accordance with the MDOT 1996 Standard Specifications for Construction. The bituminous materials are in accordance with the 1996 MDOT Specifications.
 - Bituminous Mixtures should be produced using PG 64-22 asphalt cement.
 - All aggregate base should be compacted to 95% of the Modified Proctor Density. The base materials should extend 1 foot beyond the edge of pavement.
 - Finger drains should be installed 30 feet on each side of each drainage structure.
 - Construction should be performed during the June through September time frame.

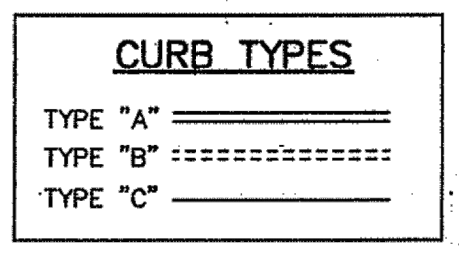
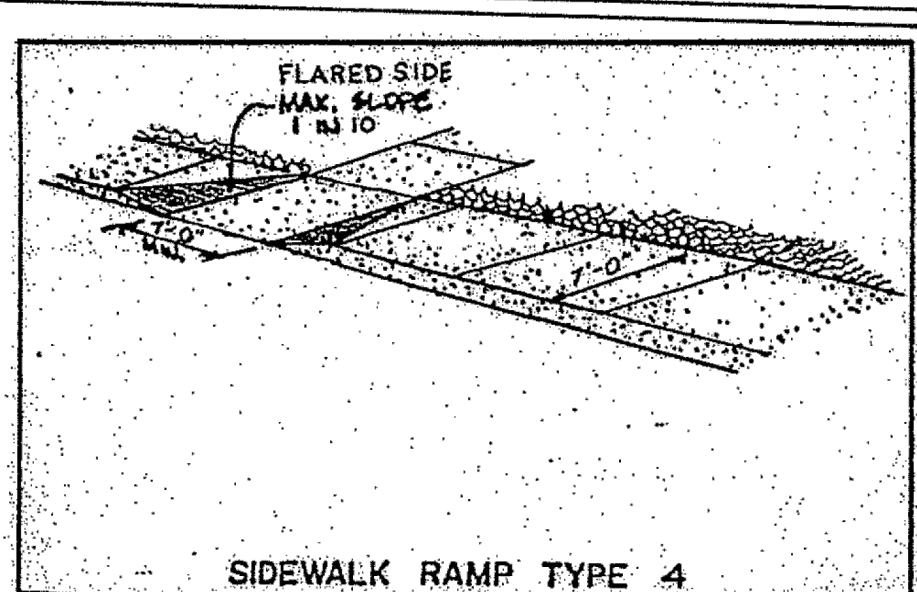
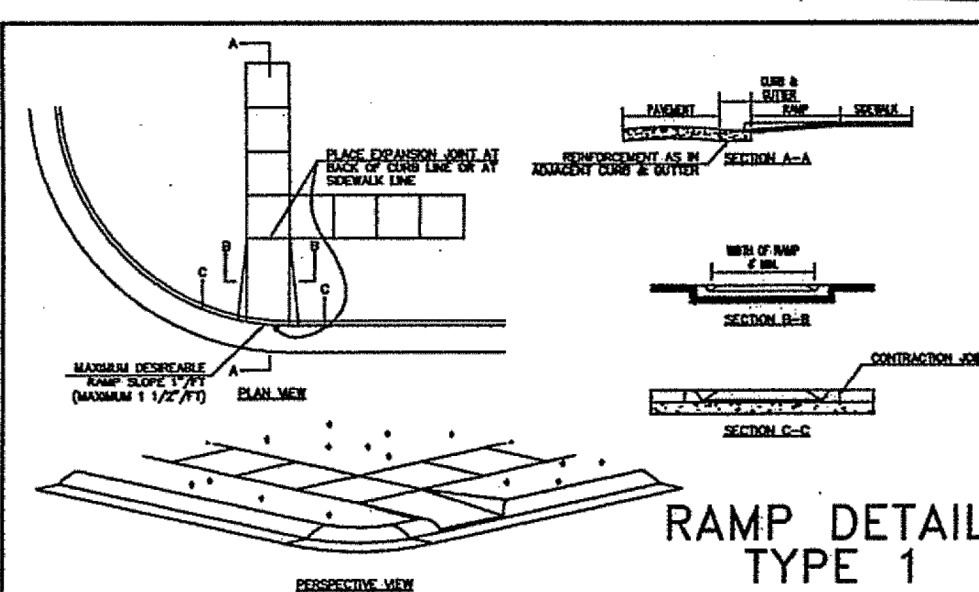
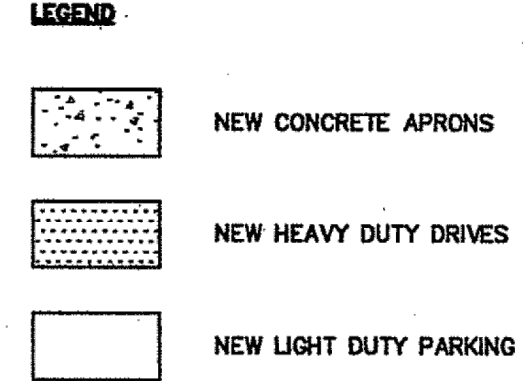

DATE BY PERMITS
8/15/01 DFD
2/14/04 DFD

REVISIONS

NO.	DATE	DESCRIPTION
1		
2		
3		
4		
5		
6		
7		
8		
9		
10		

PROJECT ARCHITECT:
CPA ARCHITECTS
28600 TELEGRAPH RD., SUITE 450
SOUTHFIELD, MI 48034 (248)354-2441
ARCHITECT'S PROJECT NO. 00-798

ZEMET WOZNIAK
P.L.L.C.
CIVIL ENGINEERS & LAND SURVEYORS
10000 WOODLAND AVENUE, SUITE 100
SOUTHFIELD, MI 48034 (248) 352-1546 FAX

MARY ELLEN KELLEY
C/O KATHRYN CARPENTER
5357 EAST RD.
DEXTER MI 48130-8334
ZONING: AR AGRICULTURAL
USE: VACANT

DIMENSION & PAVING PLAN
NEW PUBLIC SAFETY BUILDING
NORTHFIELD TOWNSHIP BUILDING AUTHORITY
NORTHFIELD, MICHIGAN

SCALE: HOR. 1" = 30'
VER. 1" = 5'
JOB NO. 01131
DRAWN BY BKD
SHEET CE-1

OHM
ARCHITECTS ENGINEERS PLANNERS
OHM-ADVISORS.COM

PRELIMINARY - NOT FOR CONSTRUCTION

ISSUED FOR: ISSUE DESCRIPTION
REVISION DESCRIPTION

PROJECT NUMBER: 015-23-020
DATE: YYYMMDD

NORTHFIELD TOWNSHIP
NORTHFIELD TOWNSHIP HALL
8360 MAIN ST

DIMENSION & PAVING PLAN BY OTHER

7

COPYRIGHT 2023 OHM ADVISORS. ALL DRAWINGS AND WRITTEN MATERIALS APPEARING HEREIN CONSTITUTE THE ORIGINAL AND UNPUBLISHED WORK OF OHM ADVISORS AND THE SAME MAY NOT BE DUPLICATED, DISTRIBUTED, OR DISCLOSED WITHOUT PRIOR WRITTEN CONSENT OF OHM ADVISORS.

UTILITY NOTE:
 THE LOCATIONS OF EXISTING UNDERGROUND UTILITIES ARE SHOWN IN AN APPROXIMATE WAY ONLY AS DISCLOSED BY AVAILABLE UTILITY COMPANY RECORDS AND HAVE NOT BEEN INDEPENDENTLY VERIFIED BY THE COMPANY. NO GUARANTEE IS EITHER EXPRESSED OR IMPLIED AS TO THE COMPLETENESS OR ACCURACY THEREOF. THE CONTRACTOR SHALL DETERMINE THE EXACT LOCATION OF ALL EXISTING UTILITIES BEFORE COMMENCING WORK, AND AGREES TO BE FULLY RESPONSIBLE FOR ANY AND ALL DAMAGES WHICH MIGHT BE OCCASIONED BY THE CONTRACTOR'S FAILURE TO EXACTLY LOCATE AND PRESERVE ANY AND ALL UNDERGROUND UTILITIES. THE CONTRACTOR SHALL NOTIFY THE DESIGN ENGINEER IMMEDIATELY IF A CONFLICT IS APPARENT.

SOIL EROSION CONTROL NOTES

A SOIL EROSION AND SEDIMENT CONTROL PERMIT SHALL BE OBTAINED BY THE CONTRACTOR FROM THE WASHINGTON COUNTY DRAIN COMMISSIONER'S OFFICE PRIOR TO THE START OF CONSTRUCTION.

A. GENERAL NOTES

- DAILY INSPECTIONS SHALL BE MADE BY THE CONTRACTOR TO DETERMINE EFFECTIVENESS OF EROSION AND SEDIMENT CONTROL MEASURES, AND ANY NECESSARY REPAIRS SHALL BE PERFORMED WITHOUT DELAY.
- EROSION AND ANY SEDIMENTATION FROM THE WORK SITE SHALL BE CONTAINED ON THE SITE AND NOT ALLOWED TO COLLECT ON ANY OFFSITE AREAS OR IN WATERWAYS. WATERWAYS INCLUDE BOTH NATURAL AND MAN-MADE OPEN DITCHES, STREAMS, STORM DRAINS, LAKES AND PONDS.
- CONTRACTOR SHALL APPLY TEMPORARY EROSION AND SEDIMENTATION CONTROL MEASURES WHEN REQUIRED AND AS DIRECTED ON THESE PLANS. HE SHALL REMOVE TEMPORARY MEASURES AS SOON AS PERMANENT STABILIZATION OF SLOPES, DITCHES AND OTHER EARTH CHANGES HAVE BEEN ACCOMPLISHED.
- STAGING THE WORK WILL BE DONE BY THE CONTRACTOR AS DIRECTED IN THESE PLANS TO ENSURE PROGRESSIVE STABILIZATION OF DISTURBED EARTH.
- IMMEDIATELY AFTER SEEDING, MULCH ALL SEEDING AREAS WITH UNWEATHERED SMALL GRAIN STRAW OR HAY, SPREAD UNIFORMLY AT THE RATE OF 1 1/2 TO 2 TONS PER ACRE, OR 100 POUNDS (2 OR 3 BALES) PER 1,000 SQUARE FEET. THIS MULCH SHOULD BE ANCHORED WITH A DISC-TYPE MULCH ANCHORING TOOL OR OTHER MEANS, AS APPROVED BY THE CITY OF NOV.
- ALL MUD/DIRT TRACKED ONTO EXISTING CITY/COUNTY/STATE ROADS FROM THIS SITE, DUE TO CONSTRUCTION, SHALL BE PROMPTLY REMOVED BY THE CONTRACTOR/BUILDER. ALL MUD/DIRT TRACKED OR SPILLED ON PAVED ROADS/SURFACES WITHIN THIS SITE SHALL BE PROMPTLY REMOVED BY THE CONTRACTOR/BUILDER.
- PERMANENT SOIL EROSION CONTROL MEASURES FOR ALL SLOPES, CHANNELS, DITCHES, OR ANY DISTURBED LAND SHALL BE COMPLETED WITHIN FIVE (5) DAYS AFTER FINAL GRADING OR THE FINAL EARTH CHANGE HAS BEEN COMPLETED. WHEN IT IS NOT POSSIBLE TO PERMANENTLY STABILIZE A DISTURBED AREA AFTER AN EARTH CHANGE HAS BEEN COMPLETED OR WHERE A SIGNIFICANT EARTH CHANGE ACTIVITY CEASES, TEMPORARY SOIL EROSION CONTROL MEASURES SHALL BE IMPLEMENTED WITHIN FIFTEEN (15) DAYS. ALL TEMPORARY SOIL EROSION CONTROL MEASURES SHALL BE MAINTAINED UNTIL PERMANENT SOIL EROSION CONTROL MEASURES ARE IMPLEMENTED. ALL PERMANENT SOIL EROSION CONTROL MEASURES WILL BE IMPLEMENTED AND ESTABLISHED BEFORE A CERTIFICATE OF OCCUPANCY IS ISSUED.

B. SEQUENCE OF CONSTRUCTION

- INSTALL DOMESTIC WELL AND TEST AS REQUIRED.
- PLACE GRAVEL AND MUD TRACKING MAT AT TEMPORARY CONSTRUCTION ENTRANCE/EXIT.
- INSTALL TREE PROTECTION FENCING AROUND EXISTING TREES TO REMAIN. CARE SHALL BE TAKEN DURING CONSTRUCTION TO SHIELD AND PROTECT THESE TREES.
- INSTALL GEOTEXTILE SILT FENCE AS PERIMETER EROSION CONTROL. PLACE ORANGE PLASTER (SNOW FENCES) TO PROTECT WATERCOURSE AND ADJACENT GRASSY/WOODS SLOPE FROM WAYWARD CONSTRUCTION TRAFFIC.
- STRIP AND GRADE FOR BUILDING, PARKING AND DRIVES. STOCKPILE TOPSOIL AND REMOVE SOIL NOT NEEDED FOR LAND BOUNDING.
- CONSTRUCT STORM SEWER, INCLUDING UNDERGROUND DETENTION SYSTEM AND SANITARY SEWER. IMMEDIATELY PLACE INLET FILTERS ON NEW DRAINAGE STRUCTURES. PLACE RIP-RAP ON THE OUTLET TO THE HORSESHOE DRAIN. STABILIZE THE DISTURBED SIDE SLOPES WITH SEED AND NATURAL FIBER EROSION CONTROL/MULCH BLANKETS STAGED IN PLACE.
- BEGIN BUILDING CONSTRUCTION.
- PREPARE PAVEMENT SUBBASE AND INSTALL CONCRETE CURBS. PLACE PAVEMENT BASE COURSE. REPAIR OR PLACE INLET FILTERS ON DRAINAGE STRUCTURES IN PAVED AREAS AS NEEDED.
- INSTALL FRANCHISED PUBLIC UTILITIES (GAS, TELEPHONE, ELECTRICITY, CABLE TELEVISION).
- FINE GRADE AND LANDSCAPE ALL DISTURBED AREAS.
- COMPLETE BUILDING CONSTRUCTION.
- PLACE PAVEMENT WEARING COURSE.
- CLEAN PAVEMENT, STORM SEWER AND UNDERGROUND DETENTION SYSTEM TANK OF ACCUMULATED SEDIMENT AND DEBRIS. REMOVE ALL TEMPORARY EROSION CONTROLS ONCE SITE HAS STABILIZED.

EROSION CONTROL LEGEND

- LIMITS OF TREE REMOVAL
- GEOTEXTILE SILT FENCE
- ORANGE TREE FENCE
- GRAVEL MUD TRACKING MAT
- "SILT-SACK" INLET FILTER
- "STREAMGAUARD EXERT II" OR "VERTI-PRO" INLET FILTER
- GRADING BUFFER
- SEED AND STAKED STRAW MULCH BLANKET
- RIP-RAP

CAUTION!!!
 EXISTING UNDERGROUND FIBEROPTIC CABLE - EXACT DEPTH & LOCATION IS NOT KNOWN

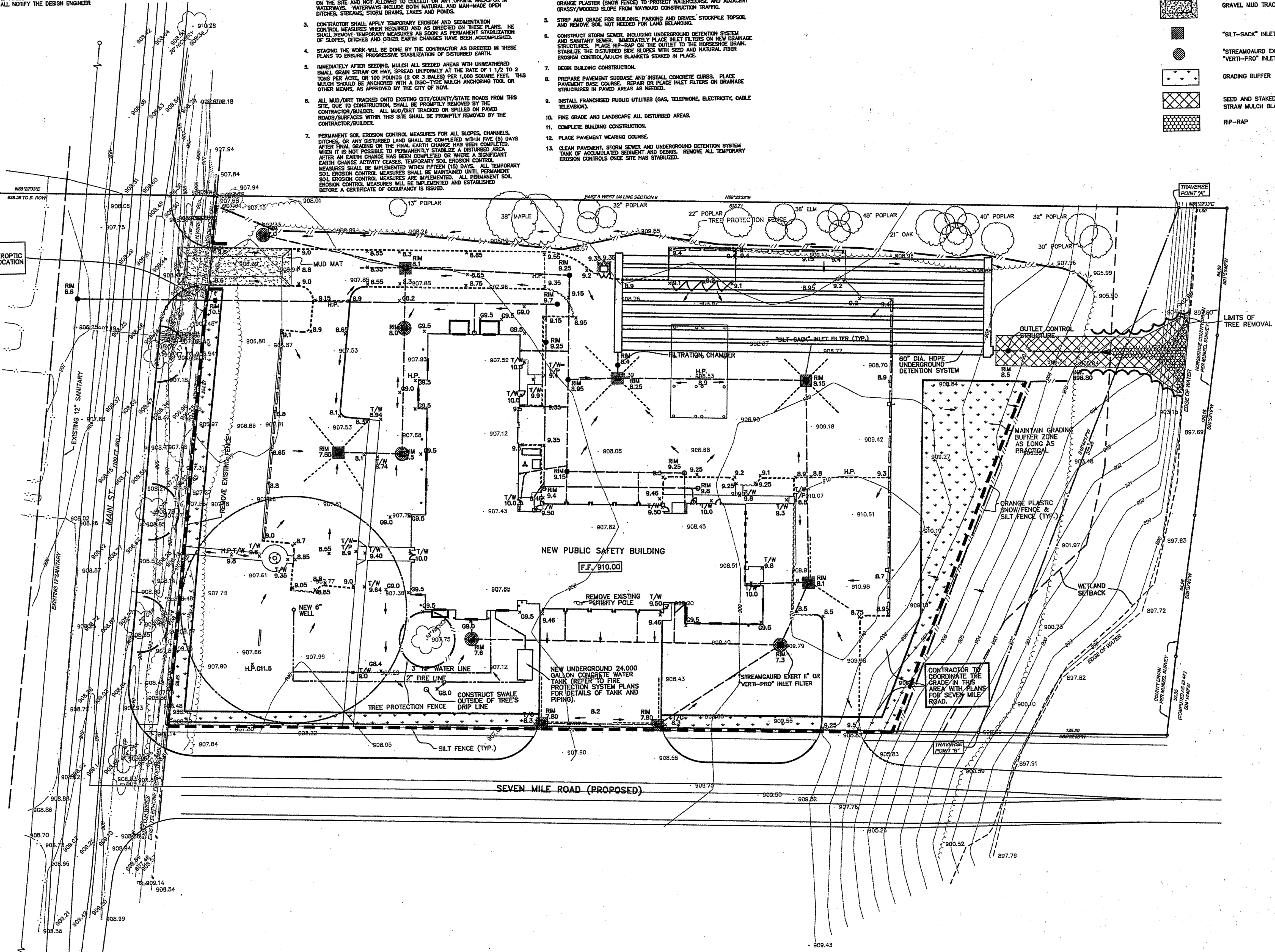

SCALE: HORIZ. 1" = 30'
 VERT. 1" = 5'
 DRAWN BY: [Signature]
 CHECKED BY: [Signature]
 PROJECT NO. 01131
 SHEET NO. CE-3

EROSION CONTROL PLAN
 NEW PUBLIC SAFETY BUILDING
 NORTHFIELD TOWNSHIP BUILDING AUTHORITY
 NORTHFIELD, MICHIGAN

PROJECT ARCHITECT:
 CPA ARCHITECTS
 2660 TELEGRAPH RD., SUITE 450
 TEL: 480-354-2441
 ARCHITECT'S PROJECT NO. 00-739

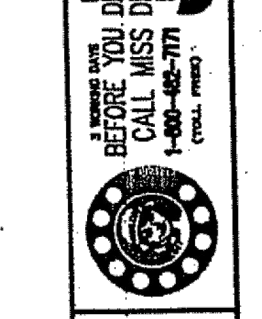

ZIMET WOZNAK
 CIVIL ENGINEER & LAND SURVEYOR
 2840 FRANKLIN ROAD
 NORTHFIELD, MI 49157
 (248) 352-3346 FAX

DATE	BY	REVISIONS
7/2/21	[Signature]	2/125



PRELIMINARY - NOT FOR CONSTRUCTION

REVISION	DESCRIPTION

PROJECT NUMBER: 015-23-020
 NORTHFIELD TOWNSHIP
 NORTHFIELD TOWNSHIP HALL
 8360 MAIN ST
 EROSION CONTROL PLAN BY OTHER

CE-3

STC 900 Precast Concrete Stormceptor®
(900 US Gallon Capacity)

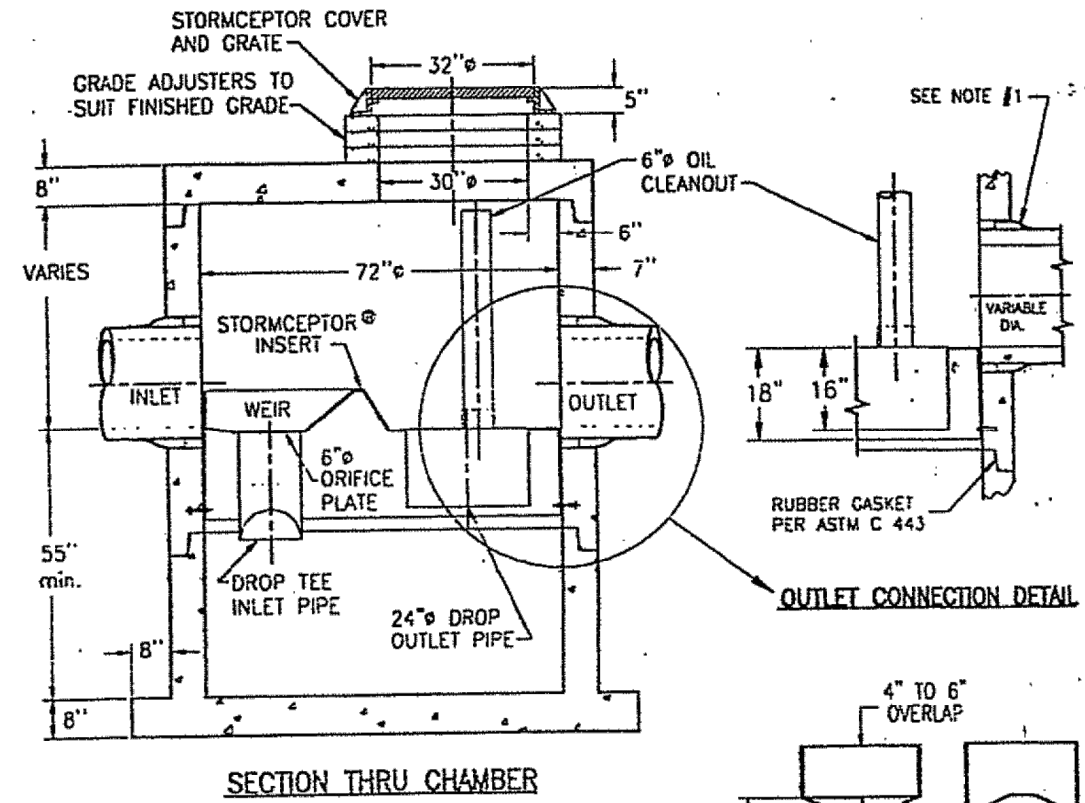

- NOTE:
1. THE USE OF FLEXIBLE CONNECTIONS IS RECOMMENDED AT THE INLET AND OUTLET WHERE APPLICABLE.
 2. THE COVER SHOULD BE POSITIONED OVER THE OUTLET DROP PIPE AND THE OIL CLEANOUT PIPE.
 3. THE STORMCEPTOR SYSTEM IS PROTECTED BY ONE OR MORE OF THE FOLLOWING U.S. PATENTS: #4985148, #5498331, #5725760, #5753115, #5849181.

Stormceptor® Disc
Disc Type Insert Detail

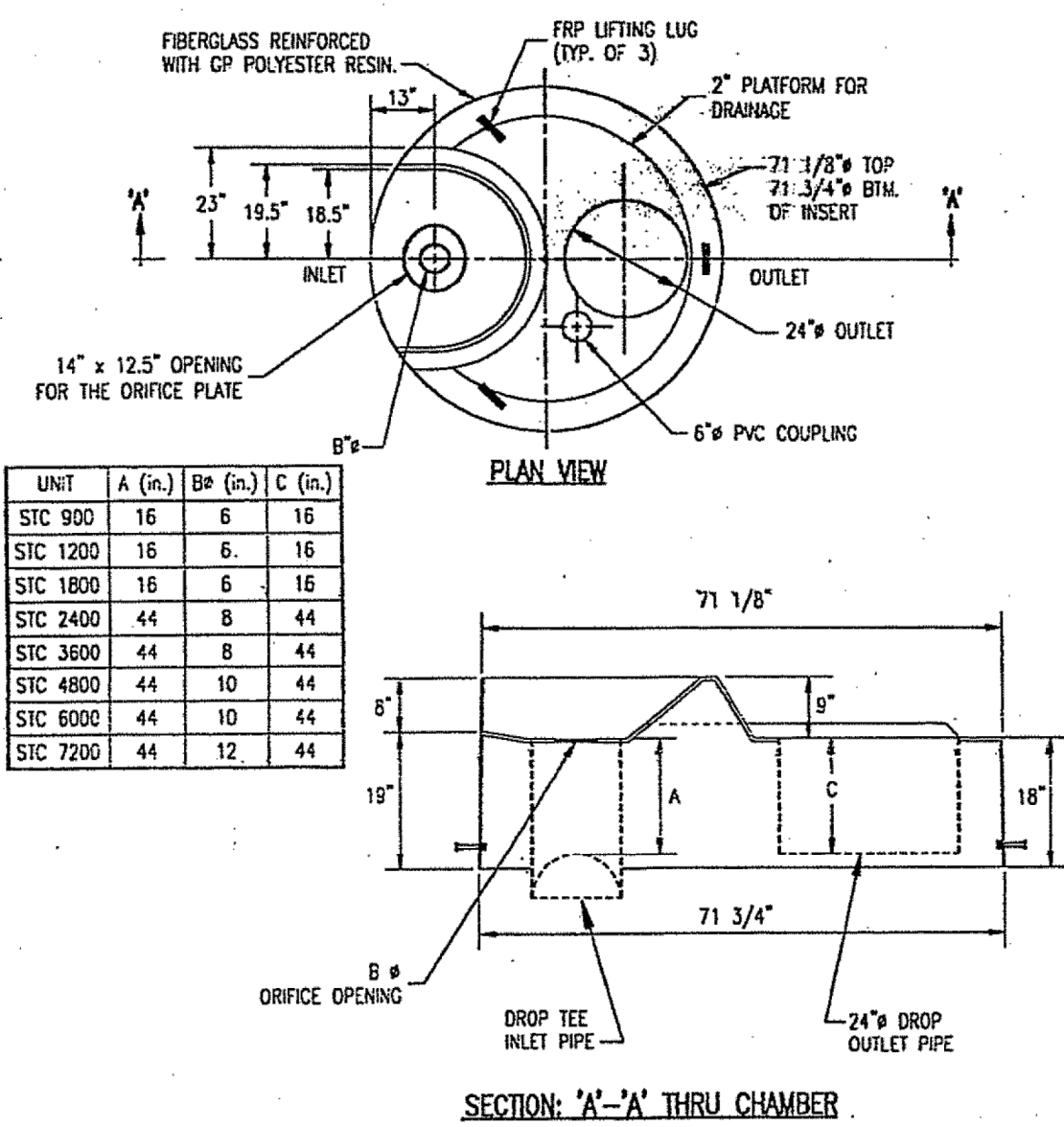

UNIT	A (in.)	B ₁ (in.)	C (in.)
STC 900	16	8	16
STC 1200	16	6	16
STC 1800	16	6	16
STC 2400	44	8	44
STC 3600	44	8	44
STC 4800	44	10	44
STC 6000	44	10	44
STC 7200	44	12	44

GRATING BY JENSEN BRIDGE & SUPPLY
OR APPROVED EQUAL

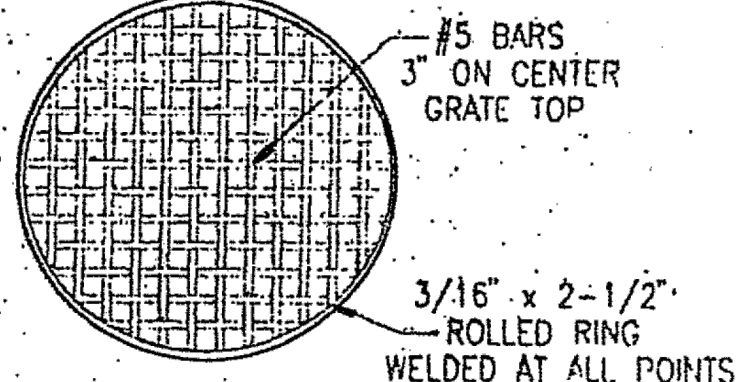

CONTROL STRUCTURE
TOP VIEW (N.T.S.)

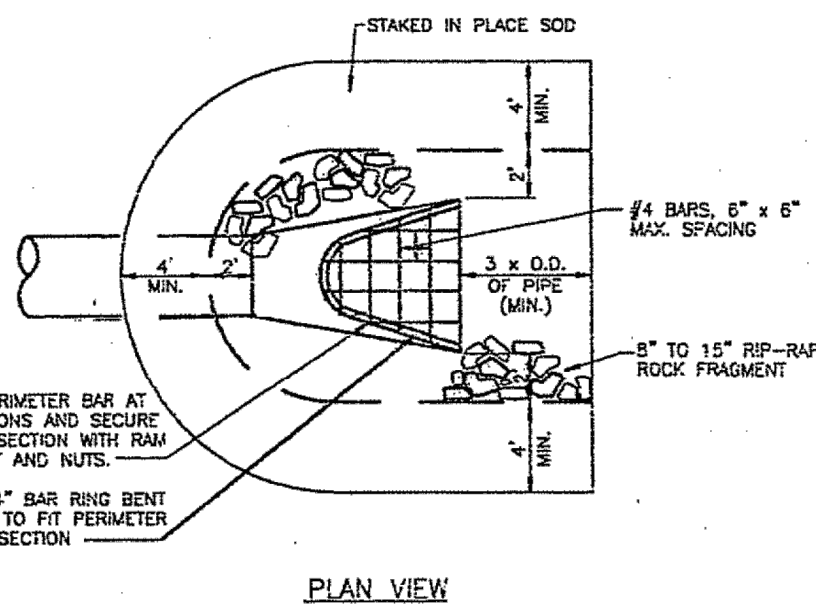
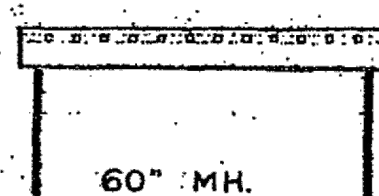

END SECTION AND BAR SCREEN DETAIL
NO SCALE

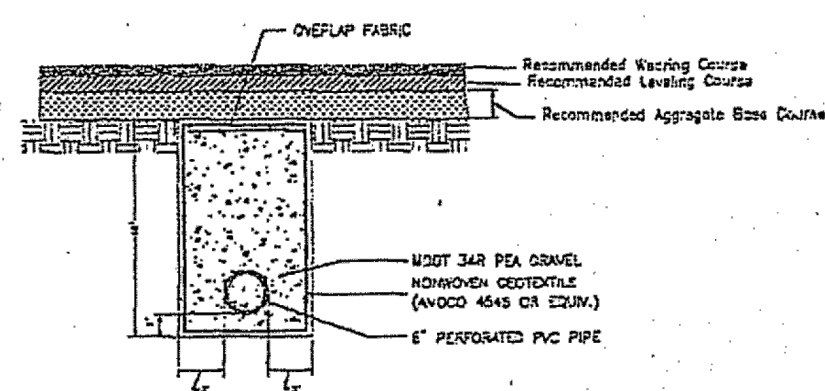
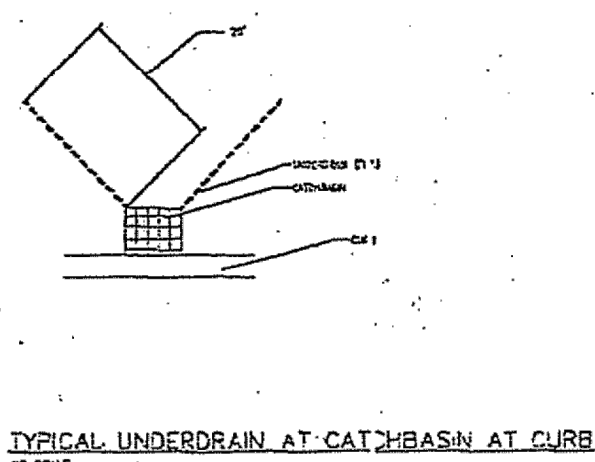
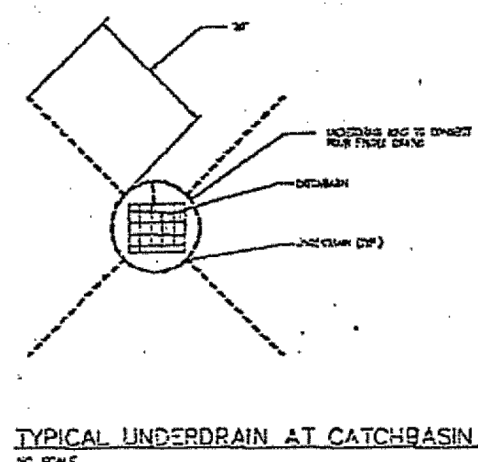
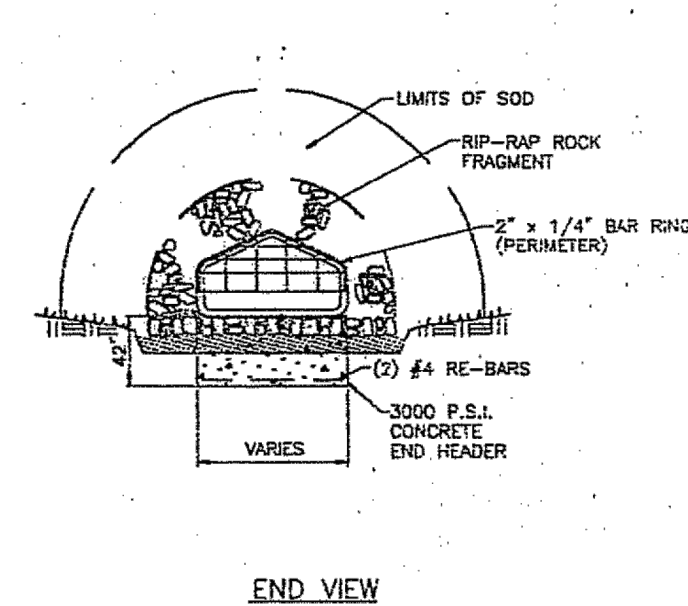
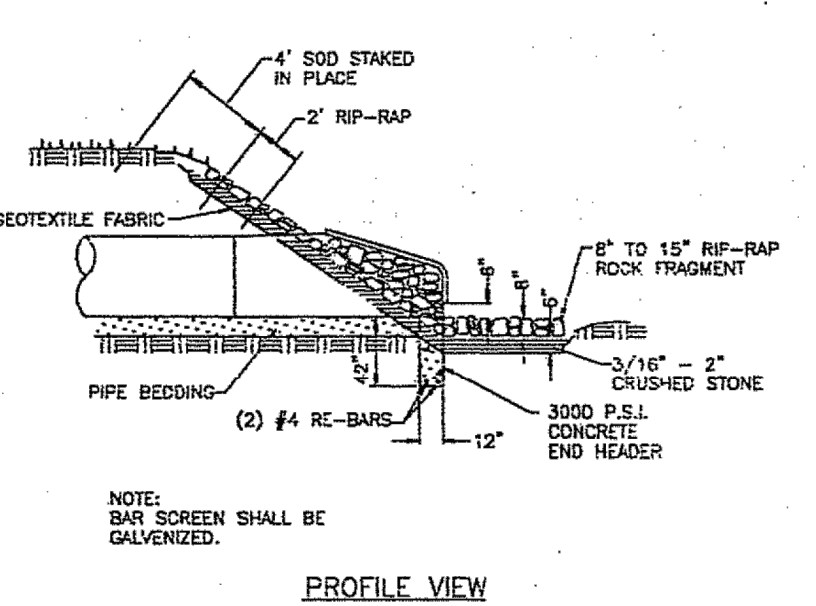

UNDERDRAIN DETAIL
NO SCALE

- NOTE:
1. RIGID UNDERDRAIN APPLICABLE UNLESS SPECIFIED OTHERWISE.
 2. ALL TRENCHES SHALL BE PROTECTED BY A 6\"/>

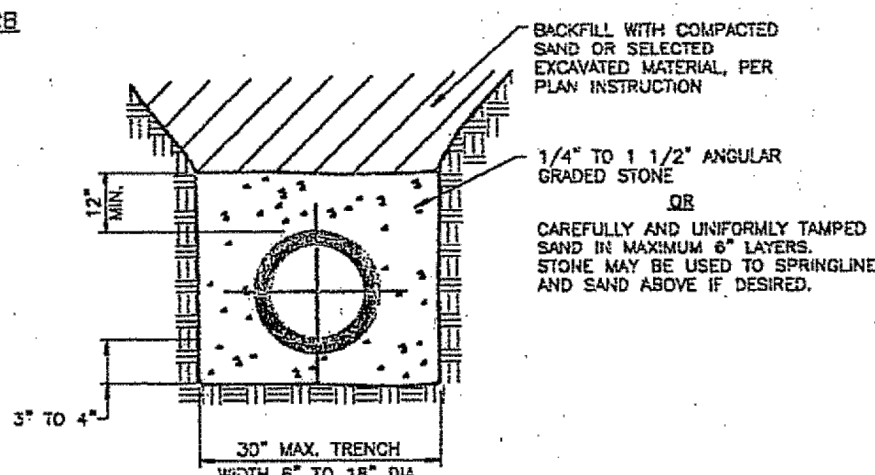

P.V.C., SOLID WALL, AND TRUSS PIPE BEDDING DETAIL
NO SCALE

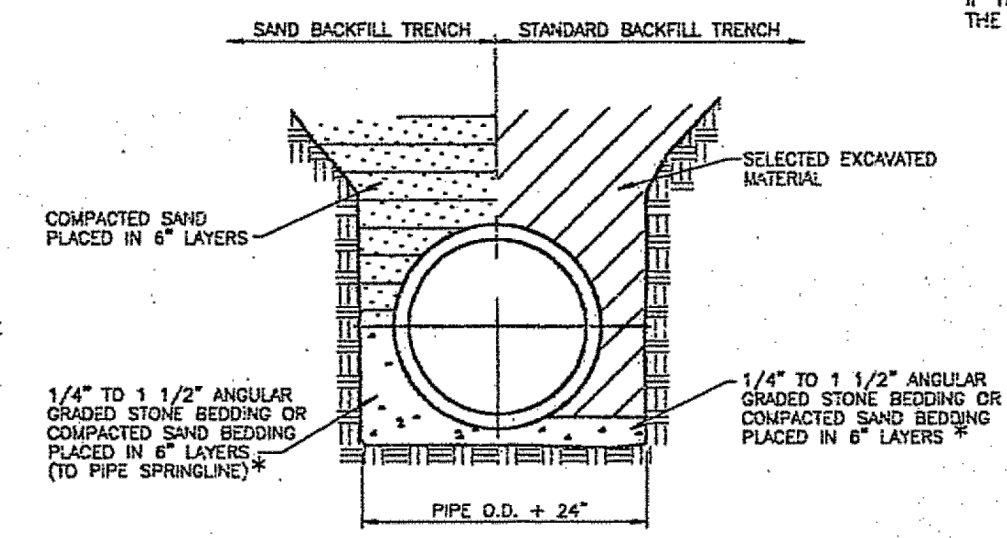

CLASS "B" BEDDING TRENCH DETAIL FOR 27" DIAMETER AND LARGER CONCRETE PIPE
NO SCALE

- *NOTE
- IN DRY, STABLE SOILS, PEASTONE (EQUIVALENT TO H.D.D.T. 34R SPECIFICATIONS) MAY BE SUBSTITUTED FOR THE STANDARD BEDDING INDICATED BELOW. IF TRENCH IS WET OR UNSTABLE A GEOTEXTILE FABRIC MUST BE USED TO LINE THE TRENCH PRIOR TO THE PLACEMENT OF THE PEASTONE.

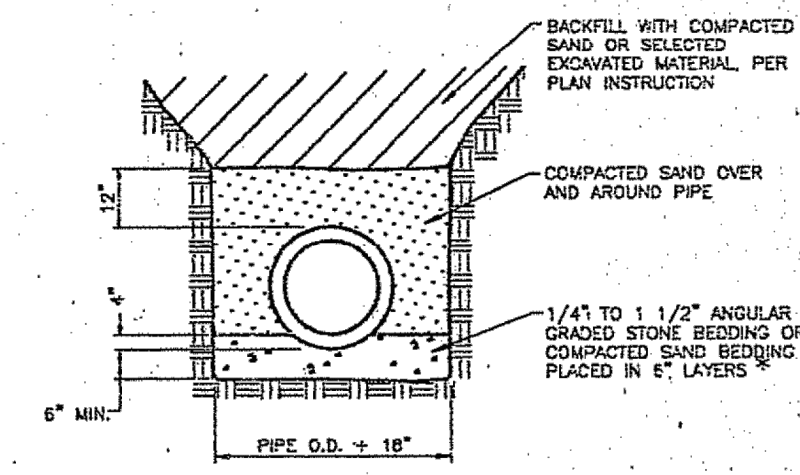

CLASS "B" BEDDING TRENCH DETAIL FOR 24" DIAMETER AND SMALLER CONCRETE PIPE
NO SCALE

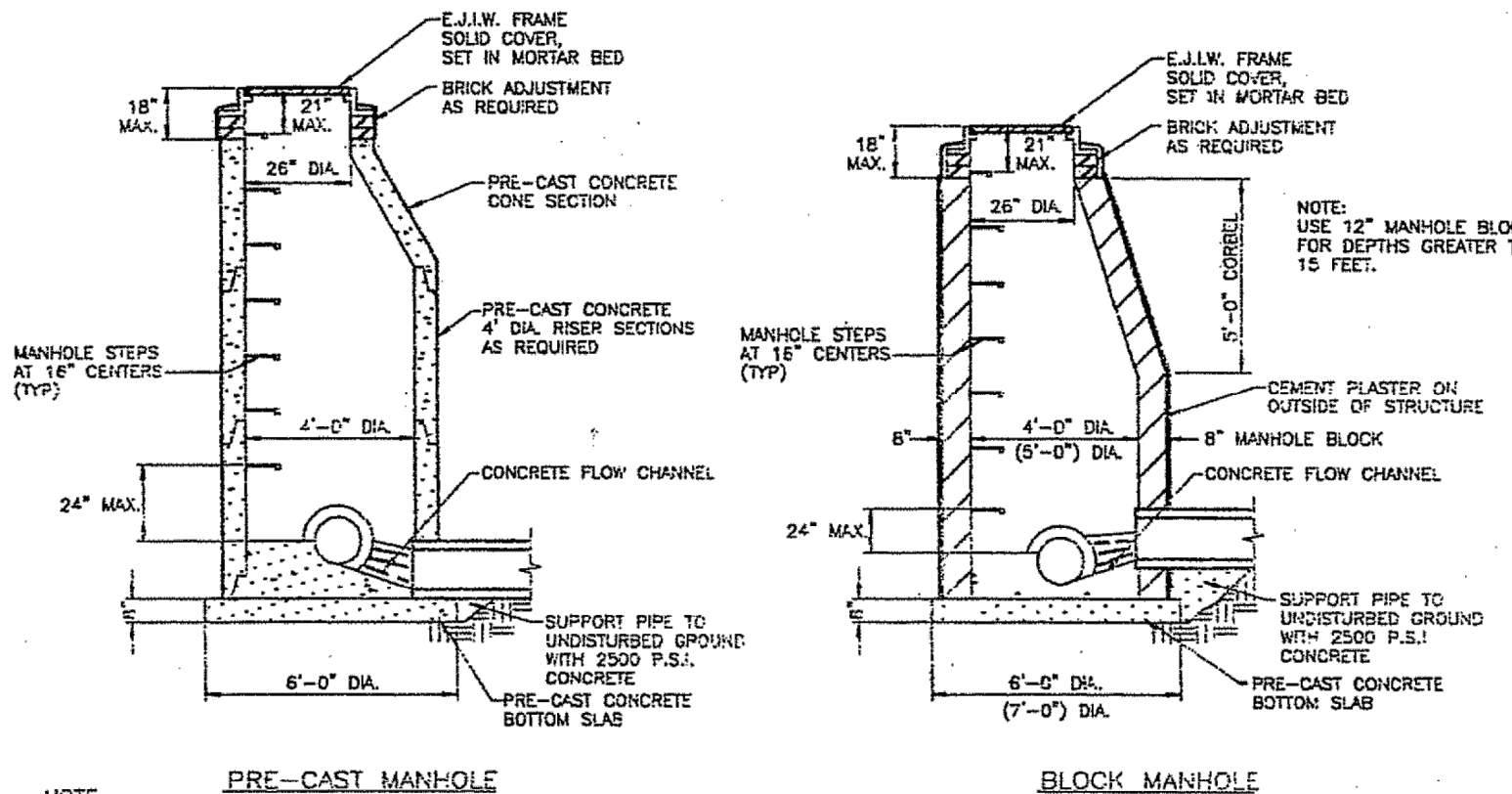

STANDARD MANHOLE DETAILS
NO SCALE

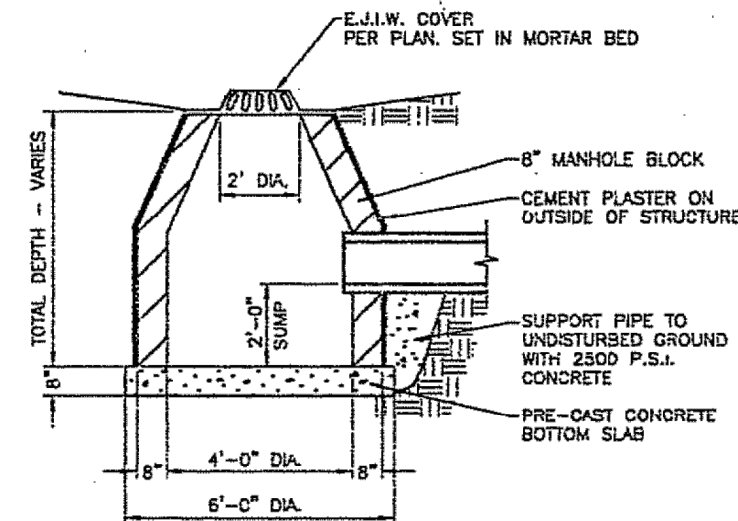

CATCH BASIN DETAIL
NO SCALE

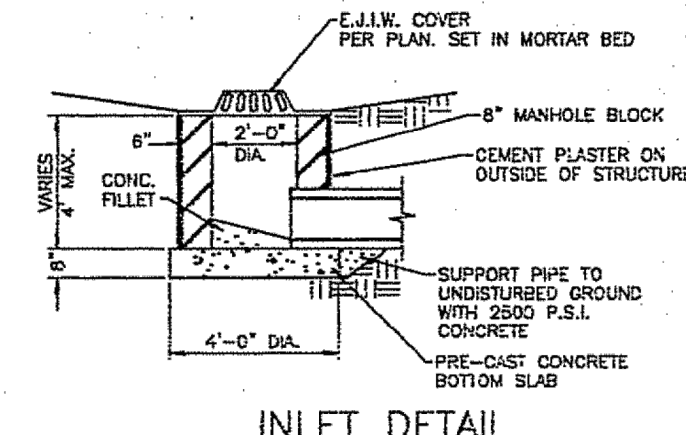

INLET DETAIL
NO SCALE

GENERAL STORM SEWER NOTES

1. Type and class of pipe shall be as specified on plans.
2. Class "B" bedding shall be used throughout, unless otherwise specified on the plan.
3. All end sections 18" and larger shall be provided with a gasketed bar screen.
4. CONCRETE PIPE REQUIREMENTS:
 - The contractor shall provide reinforced concrete pipe as specified on the plans.
 - All reinforced concrete pipe shall have modified grooved tongue joints with o-ring type rubber gasket, per A.S.T.M. specifications C443.
 - The inside joints of pipe sizes over 27" diameter shall be pointed up with mortar upon completion of backfilling operations.
5. SUMP PUMP LEAD REQUIREMENTS:
 - All sump pump leads connected to a county drain shall be pre-manufactured.
 - Sump pump mains and leads shall be a SDR 35, non-perforated, solid wall, PVC, Arma-Truss Pipe, or approved equal, with premium joints.
 - Ends of all 4" sump pump leads shall be temporarily capped and their location staked, witnessed and recorded.
 - All sump pump leads to be taken to the property line, easement line or as indicated on the plan.
 - Sump pump cleanouts shall be a minimum inside diameter of 24" and be constructed at changes of alignment, ends of sump pump mains or as indicated on the plan.

SCALE: 1" = 4'-0"
DATE: 01/13/24
PROJECT ARCHITECT: STORM SEWER DETAILS
NEW PUBLIC SAFETY BUILDING
NORTHFIELD TOWNSHIP BUILDING AUTHORITY
WHITMORE LAKE, MICHIGAN

PROJECT ARCHITECT:
CDPA ARCHITECTS
28600 TELEGRAPH RD., SUITE 450
SOUTHFIELD, MI 48034 (248)358-2441
ARCHITECT'S PROJECT NO. 00-739

ZIMET & WOZNIAK
CIVIL ENGINEERS & LAND SURVEYORS
5000 TELEGRAPH RD., SUITE 400
SOUTHFIELD, MI 48034
(248) 352-0150 (248) 352-1348 FAX

DATE	BY	REVISIONS
01/13/24	PM	1. PRELIMINARY
01/13/24	DR	2. REVISIONS
01/13/24	DR	3. REVISIONS



PRELIMINARY - NOT FOR CONSTRUCTION

REVISION	DESCRIPTION	DATE

PROJECT NUMBER: 015-23-020
NORTHFIELD TOWNSHIP
NORTHFIELD TOWNSHIP HALL
8360 MAIN ST
STORM SEWER DETAILS BY OTHER